

# MODEL 740 CARBURETOR

1981 ESCORT/LYNX

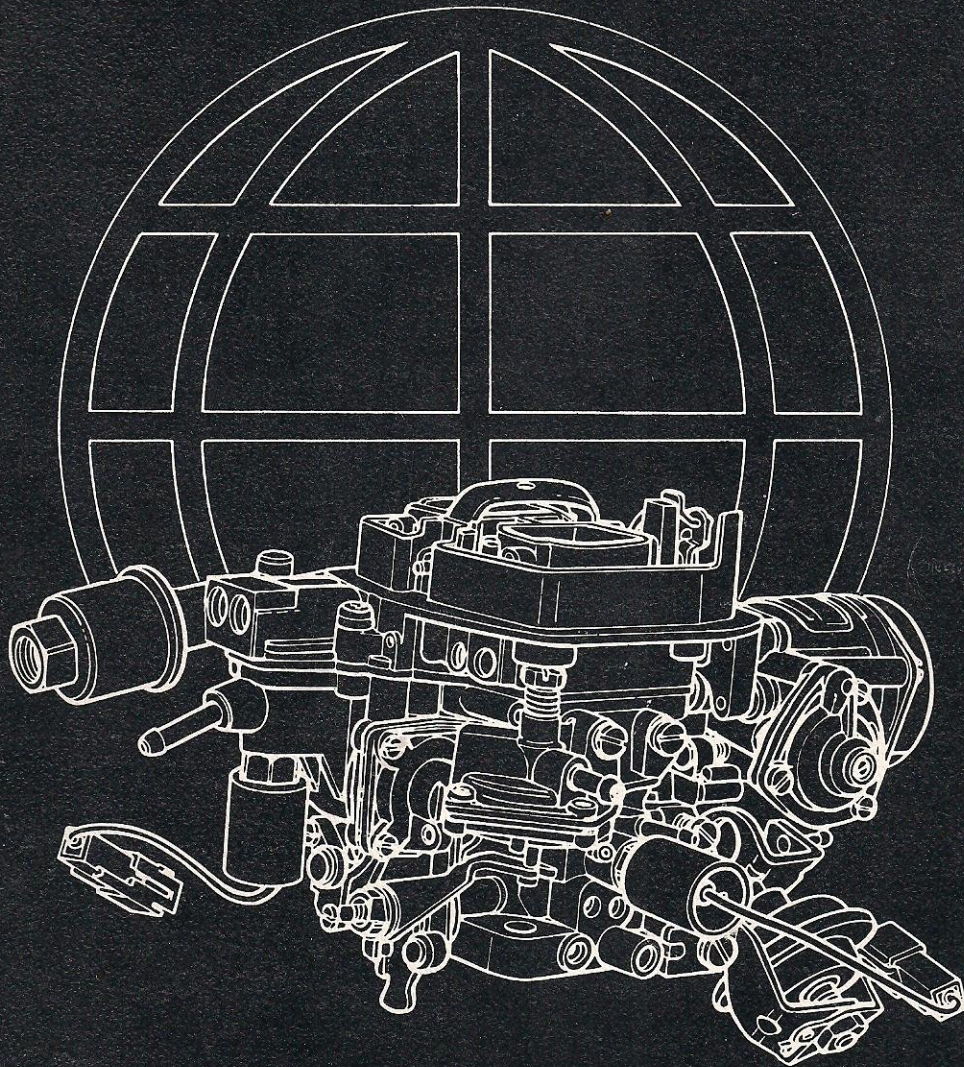

Ford Parts and Service Division  
Training and Publications Department

www.carburetor-parts.com  
**TABLE OF CONTENTS**

<b>INTRODUCTION</b> .....	3
MODEL 740 CARBURETOR VIDEO REFERENCE BOOK .....	3
<b>GENERAL DESCRIPTION</b> .....	4
MODEL 740 CARBURETOR .....	4
RELATED COMPONENTS .....	6
Vacuum Solenoid .....	6
Power Steering Pressure Sensor .....	6
Altitude Compensator .....	6
<b>OPERATION</b> .....	7
<b>FUEL INLET SYSTEM</b> .....	7
<b>IDLE and OFF-IDLE SYSTEMS</b> .....	7
Idle System .....	7
Off-Idle System .....	8
Idle Shutoff Solenoid .....	8
<b>MAIN METERING SYSTEM</b> .....	8
<b>PRIMARY ENRICHMENT SYSTEM</b> .....	9
<b>SECONDARY ENRICHMENT SYSTEM</b> .....	9
<b>ACCELERATOR PUMP SYSTEM</b> .....	10
<b>ALTITUDE COMPENSATION SYSTEM</b> .....	10
<b>DISASSEMBLY and ASSEMBLY</b> .....	11
<b>NEW BRAIDED FUEL LINE</b> .....	11
<b>DISASSEMBLY</b> .....	12
Removing Air Horn .....	12
Removing Adjustment Limiting Rivets and Screws .....	13
Removing Adjustment Limiting Plugs .....	15
Removing Jets and Air Bleeds .....	16
Removing Accelerator Pump Nozzle .....	17
Removing Idle Fuel Shutoff Solenoid .....	17
Removing Fuel Bowl Vent Solenoid .....	17
Removing Throttle Kicker .....	18
Removing Accelerator Pump .....	18
Removing Pulldown Diaphragm .....	18
Removing Power Enrichment Valve Diaphragm .....	19
Removing Choke Assembly .....	19
Cleaning .....	19
<b>ASSEMBLY</b> .....	20
<b>INSTALLING ADJUSTMENT LIMITING RIVETS AND PLUGS</b> .....	21
Adjustment Limiting Rivets .....	21
<b>CHOKE PULLDOWN CLEARANCE</b> .....	22
Choke Plate Vacuum Pulldown Check/Adjust .....	22
<b>ON-CAR ADJUSTMENTS</b> .....	23
Engine Preparation .....	23
Thermactor System Preparation .....	24
<b>CURB IDLE SPEED CHECK/ADJUST</b> .....	24
<b>ADJUSTING DASHPOT</b> .....	25
<b>FAST IDLE SPEED CHECK/ADJUST</b> .....	26
<b>THROTTLE KICKER</b> .....	27
<b>IDLE FUEL MIXTURE-PROPANE ENRICHMENT METHOD</b> .....	28
Adjustment Limiting Plugs .....	29
<b>CHECKING ALTITUDE COMPENSATION SYSTEMS</b> .....	30
<b>SPECIAL TOOLS REQUIRED</b> .....	30

## INTRODUCTION

### MODEL 740 CARBURETOR VIDEO REFERENCE BOOK

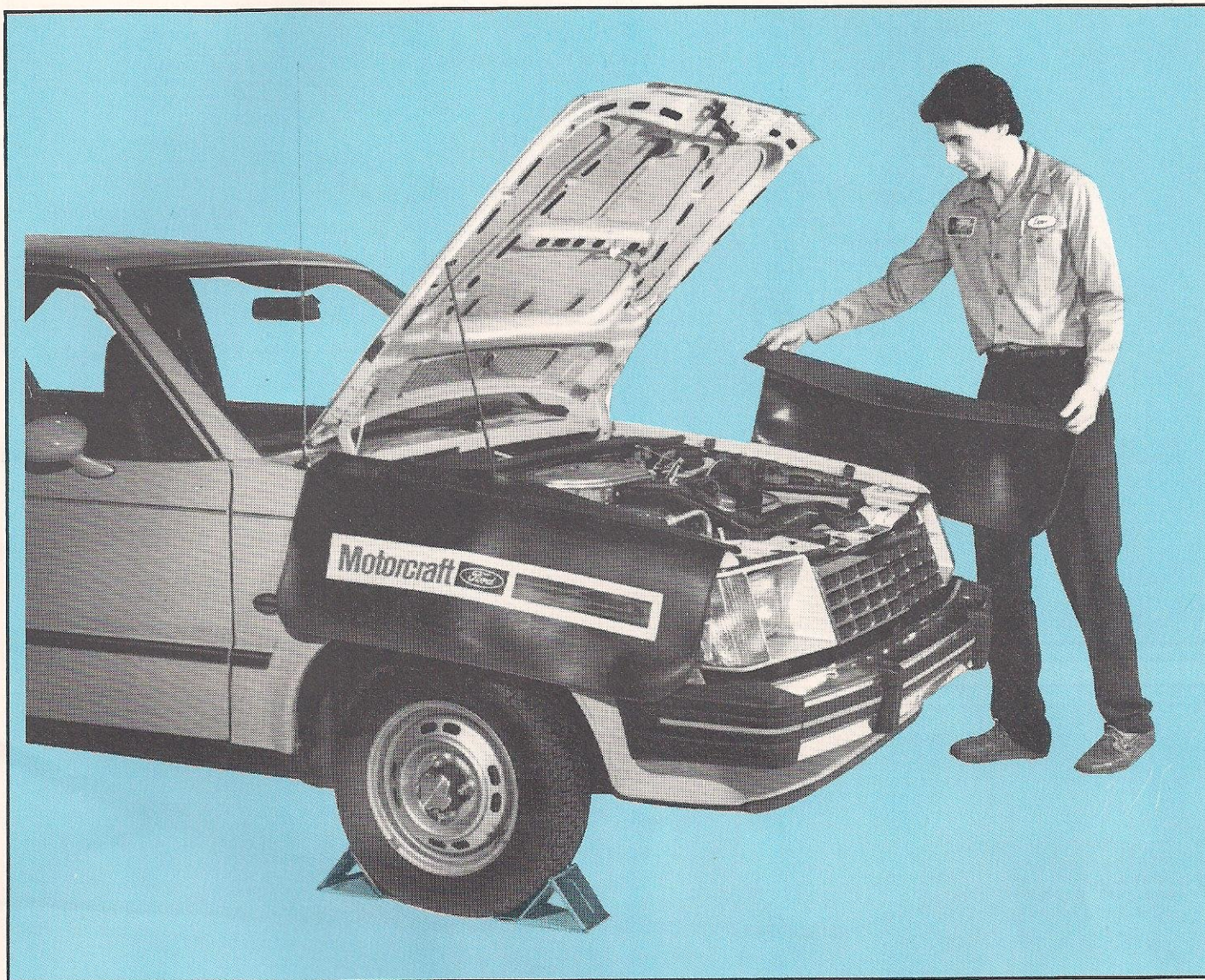

This book is designed to be used with the video film describing the operation and servicing of the Model 740 carburetor used on the 1981 Escort/Lynx vehicles. In it you will find information concerning:

- How the model 740 operates
- How to adjust it
- Simple diagnosis
- How to rebuild it with the Motorcraft carburetor rebuilding kit

You will also find additional charts, illustrations and operations not suitable for a video presentation of this length.

The material presented here is drawn from the 1981 Escort/Lynx Shop Manual, new model training materials and engineering releases. It is intended as a general introduction to the model 740 carburetor, and not as a complete service manual. Always refer to the latest technical information when servicing the model 740 carburetor or related systems.

www.carburetor-parts.com  
**GENERAL DESCRIPTION**

**MODEL 740 CARBURETOR**

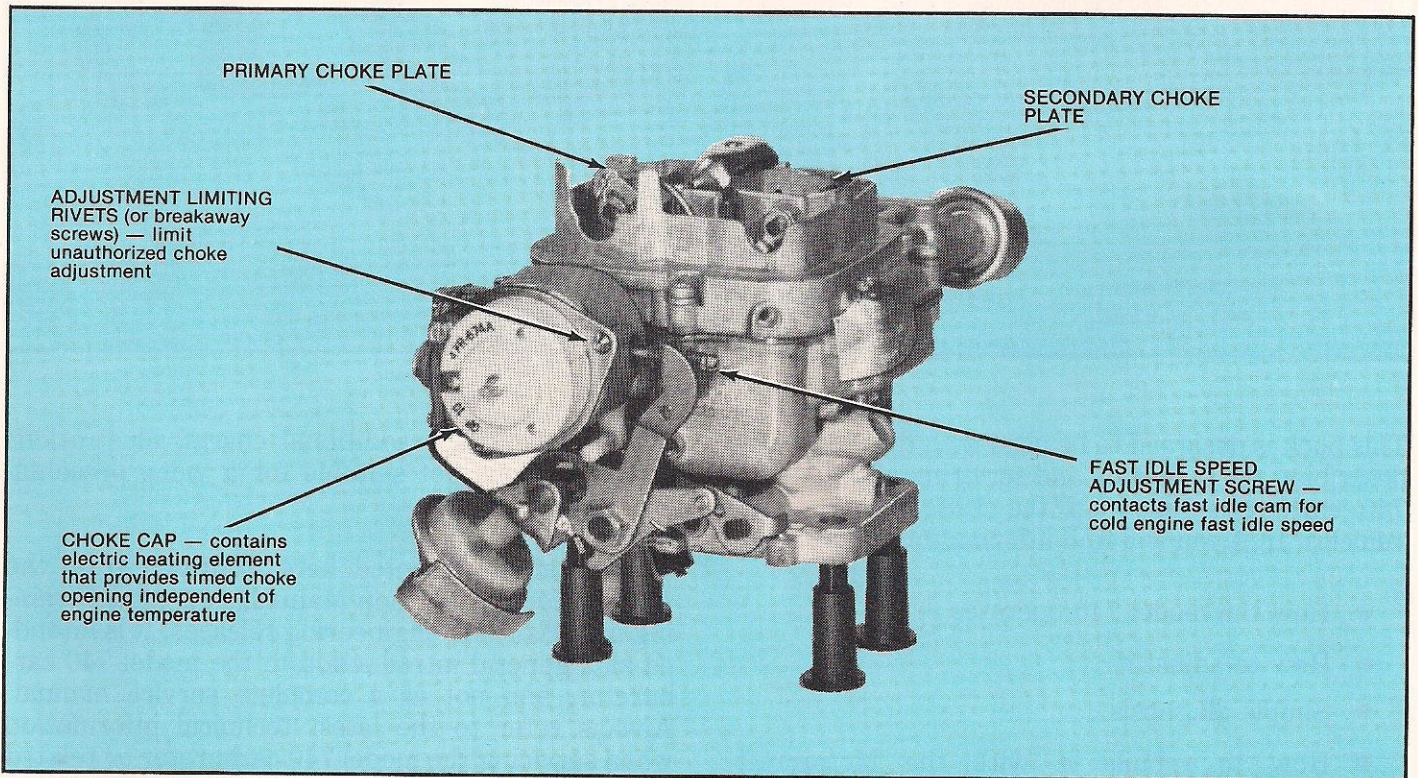
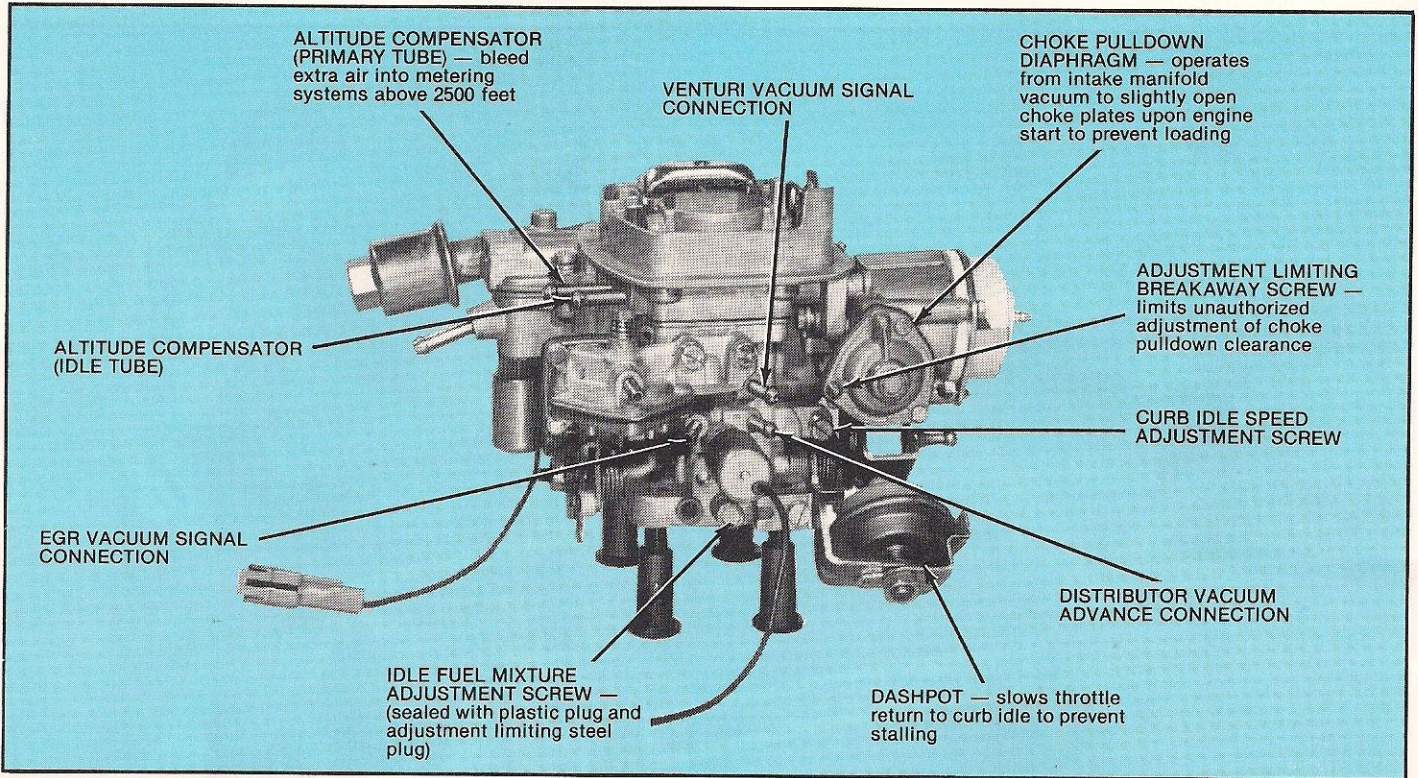

## MODEL 740 CARBURETOR

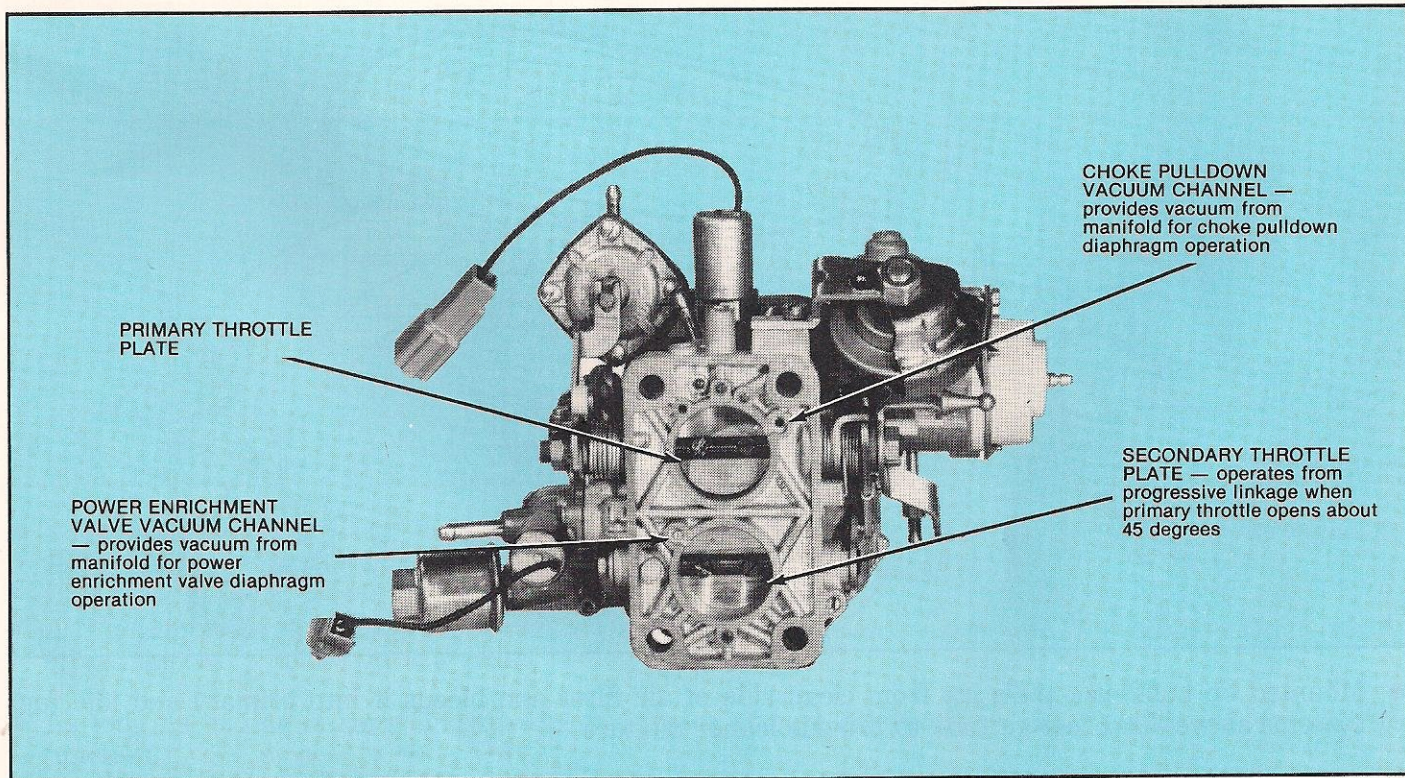
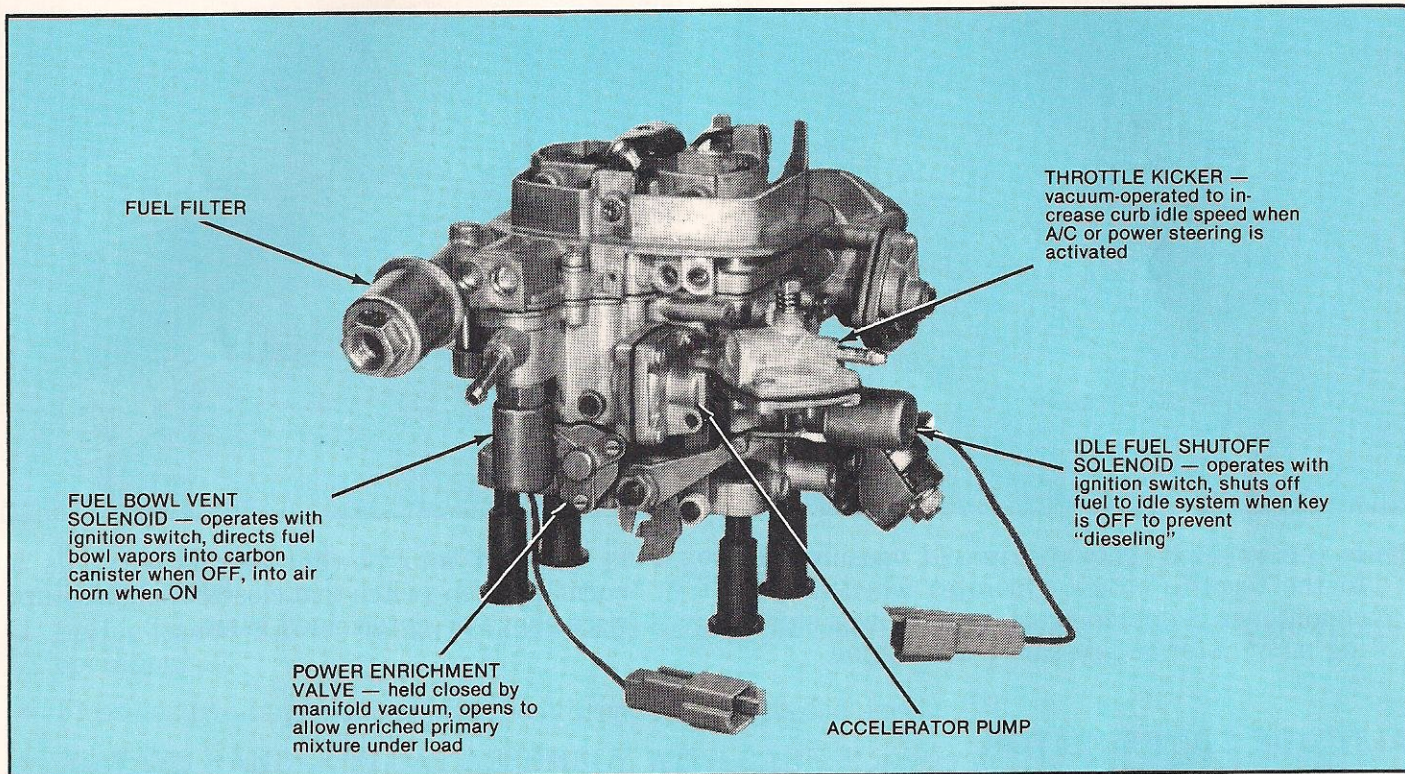

# GENERAL DESCRIPTION

www.carburetor-parts.com

## RELATED COMPONENTS

### VACUUM SOLENOID

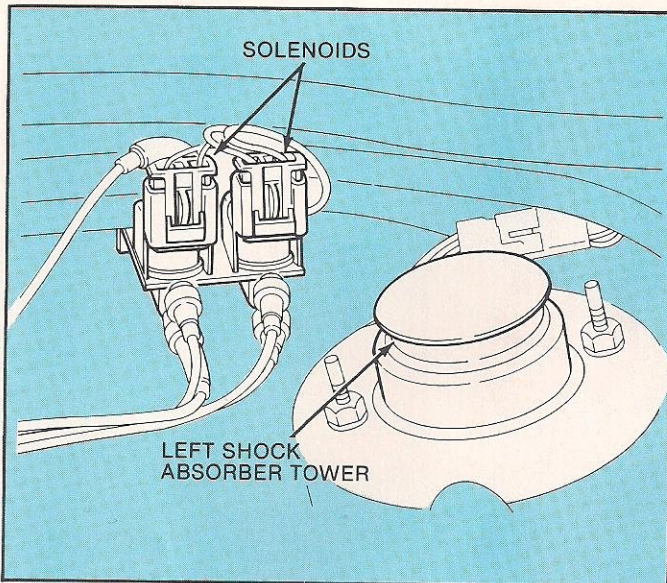

- Is connected to engine manifold vacuum and to the throttle kicker. Operates when (1) air conditioner clutch engages, or (2) power steering pump internal pressure loads engine.

### POWER STEERING PRESSURE SENSOR

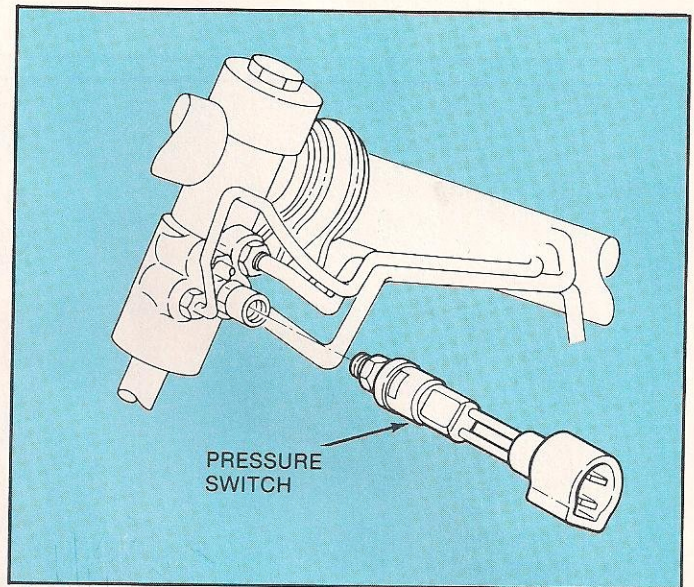

- Is installed into power steering gear. Is a normally open switch that closes when pressure rises above predetermined value.

### ALTITUDE COMPENSATOR

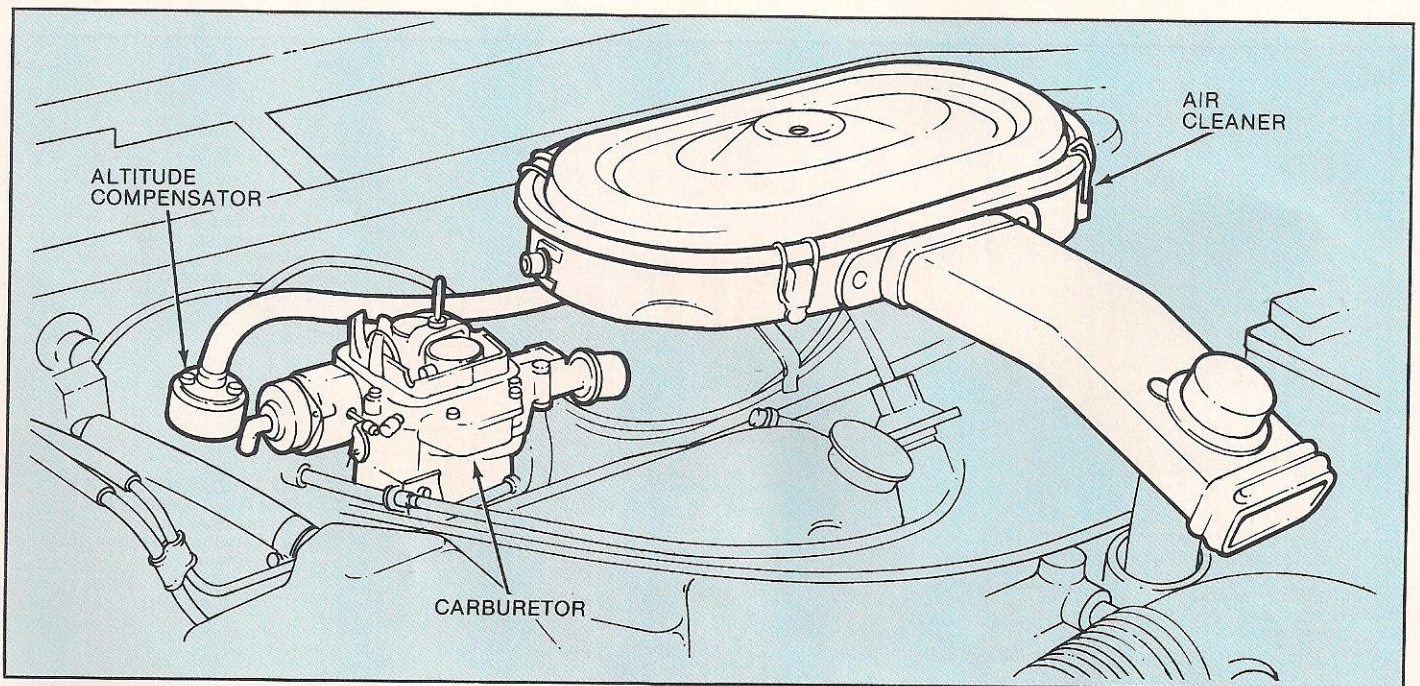

- Mounted on bulkhead, pulls air from clean side of air filter and bleeds it into primary and idle fuel systems above 3000 feet altitude to provide leaner mixture.

## FUEL INLET SYSTEM

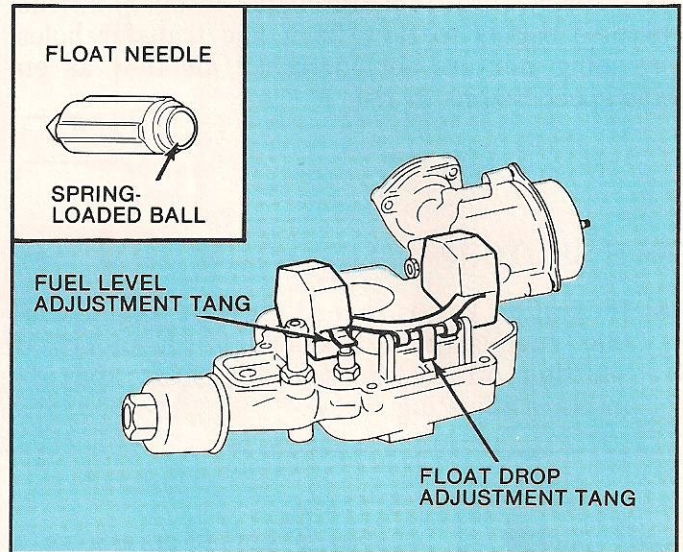
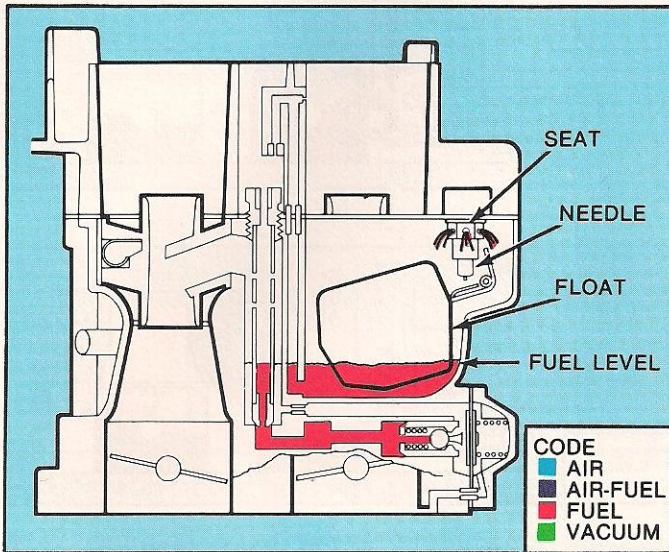

- Fuel enters through fuel filter, flows past needle and seat — regulated by float level — and fills fuel bowl.
- Spring-loaded ball in needle damps needle action; prevents flutter, especially during part-throttle operation.
- Float has two tangs; one adjusts float drop, one adjusts fuel level.
- ALWAYS HANDLE FLOAT ASSEMBLY WITH CARE; it is very delicate and easily damaged.

## IDLE AND OFF-IDLE SYSTEMS

### IDLE SYSTEM

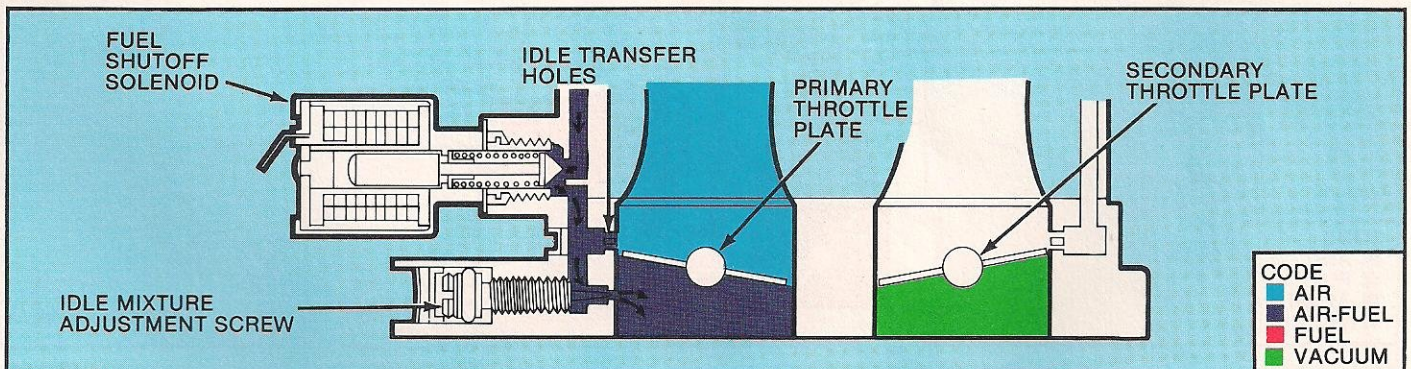

- Fuel flows from fuel bowl through primary main metering jet into main well, then up through idle fuel restriction, mixing with air entering through primary idle air bleed.
- Air-fuel mixture then flows downward past shutoff solenoid, past the idle mixture adjustment screw, and exits below throttle plate.
- As long as engine is running with throttle plates at curb idle position, idle system will continue to function.

## OFF-IDLE SYSTEM

As primary throttle plate begins to open, air/fuel mixture begins to flow from idle transfer holes, providing mixture for increased air flow as engine speed begins to rise.

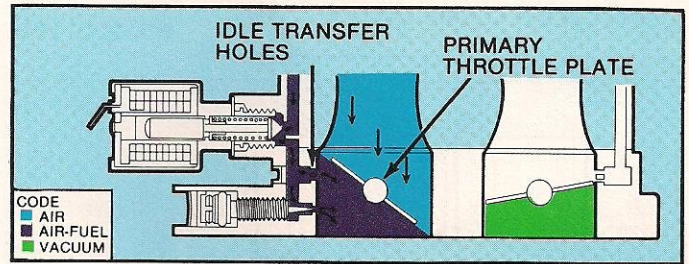

## IDLE SHUTOFF SOLENOID

- If ignition key is turned OFF at engine idle, idle fuel shutoff solenoid is de-energized, shutting off fuel to transfer holes and idle mixture adjusting screw.

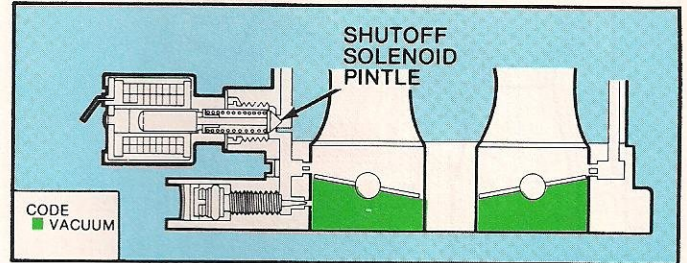

## MAIN METERING SYSTEM

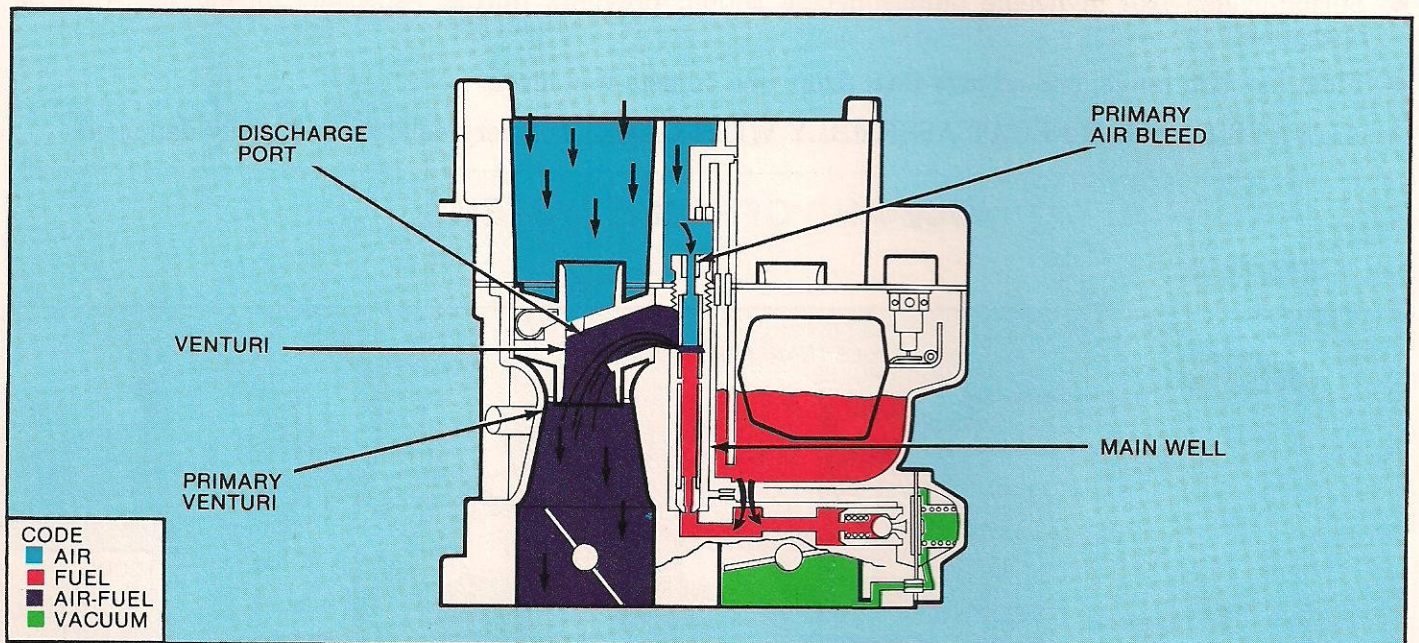

- As primary throttle plate continues to open, air velocity increases in primary throttle bore.
- Air pressure on fuel in bowl, and reduced pressure in primary venturi due to increased flow, causes fuel to flow from fuel bowl through primary jet into main well.
- Air, flowing through primary air bleed, mixes with fuel in ratio related to air speed through venturi.
- Air/fuel mixture is discharged into venturi air stream through port in booster venturi.



PRIMARY ENRICHMENT SYSTEM

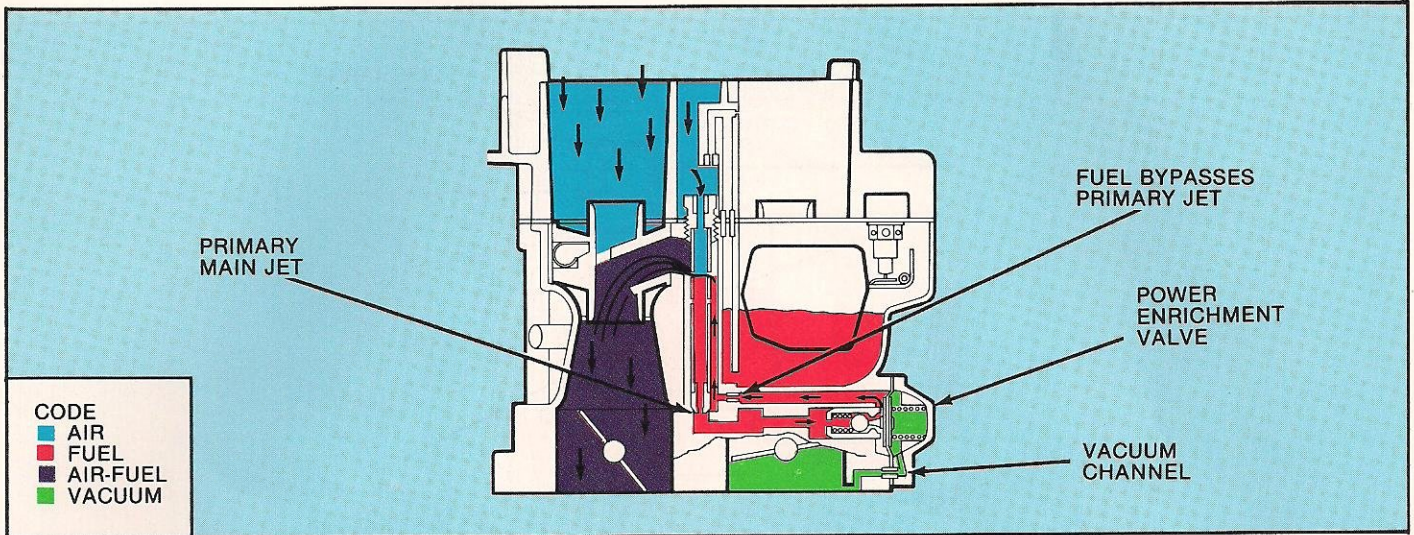

- Operates under heavy engine loads.
- Vacuum-operated power enrichment valve releases as engine manifold vacuum drops 6-3" Hg., allowing fuel to flow through valve, bypassing primary jet.
- Additional fuel metered through power enrichment valve causes richer mixture in primary main metering system.

SECONDARY ENRICHMENT SYSTEM

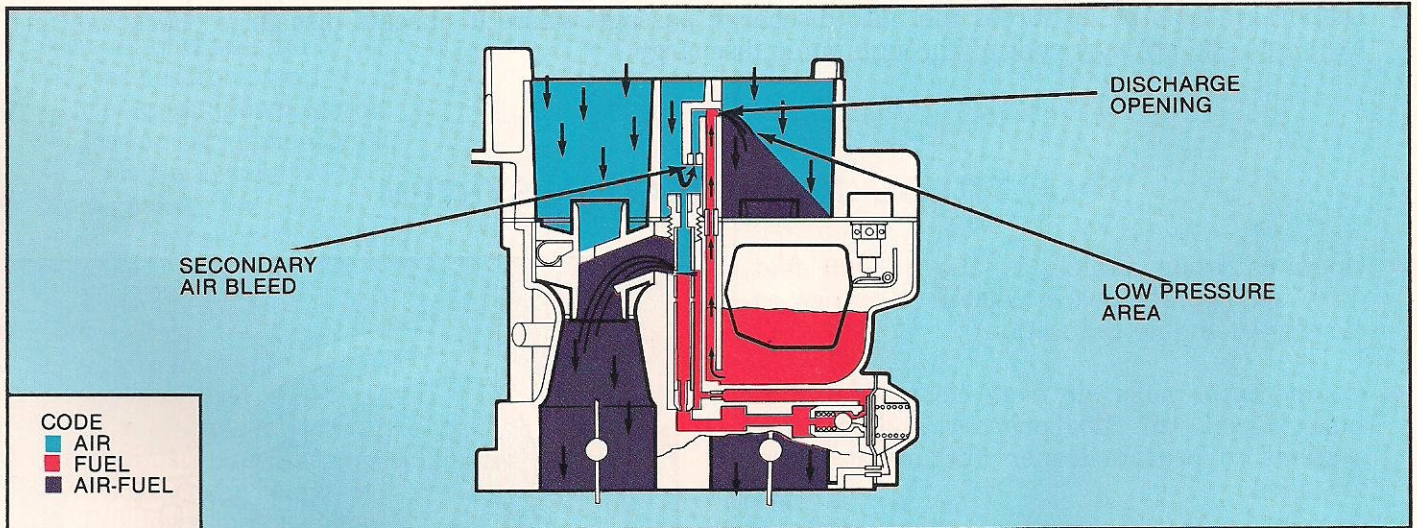

- Secondary enrichment system operates when air in secondary bore reaches high velocity near wide open throttle.
- Low pressure at discharge opening of air horn causes fuel to flow from bowl, through vertical channel, mixing with air entering calibrated air bleed.
- Mixture discharges through opening in air horn, above venturi.
- Sometimes called "pullover" system because air/fuel mixture is "pulled over" from fuel bowl at high air flow.

## ACCELERATOR PUMP SYSTEM

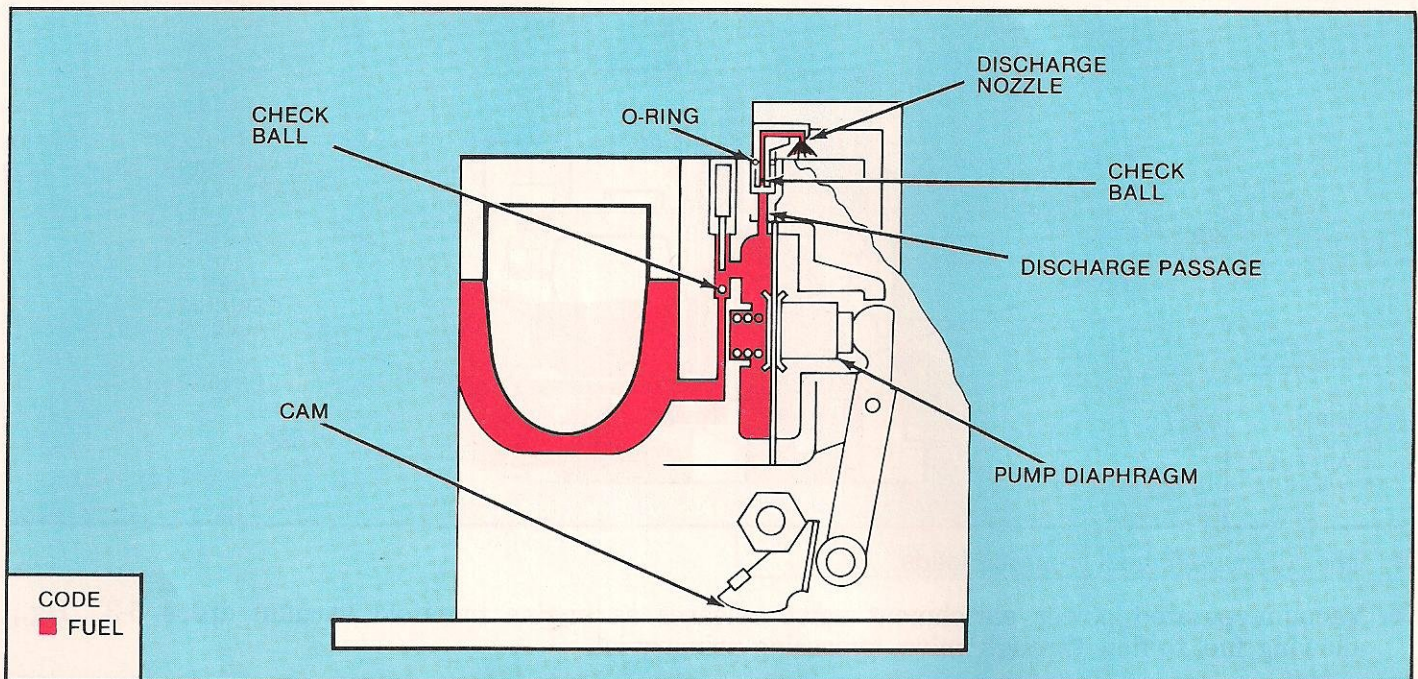

- Pump operates when primary throttle shaft rotates through two-step cam on throttle shaft. Second step provides discharge when secondary throttle plate opens.
- Provides richer air/fuel mixture when throttle plates are quickly opened.
- Diaphragm-type pump forces fuel into discharge passage where it unseats discharge check ball and exits into the primary venturi through pump discharge.

## ALTITUDE COMPENSATION SYSTEM

- Operates when vehicle is above 3000 feet, does not operate below 2500 feet (varies according to engine calibration).
- Compensator pulls air from clean side of air filter, bleeds air into primary and idle fuel systems to provide leaner mixture at higher altitudes.

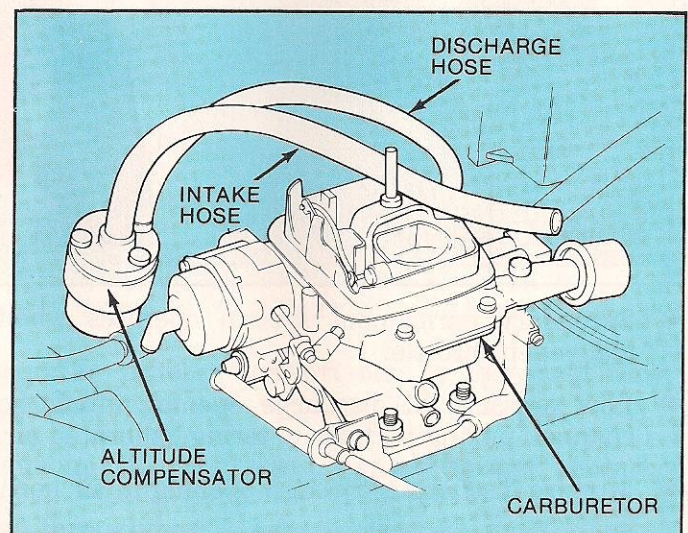

# DISASSEMBLY AND ASSEMBLY

## MOTORCRAFT TUNE-UP KIT

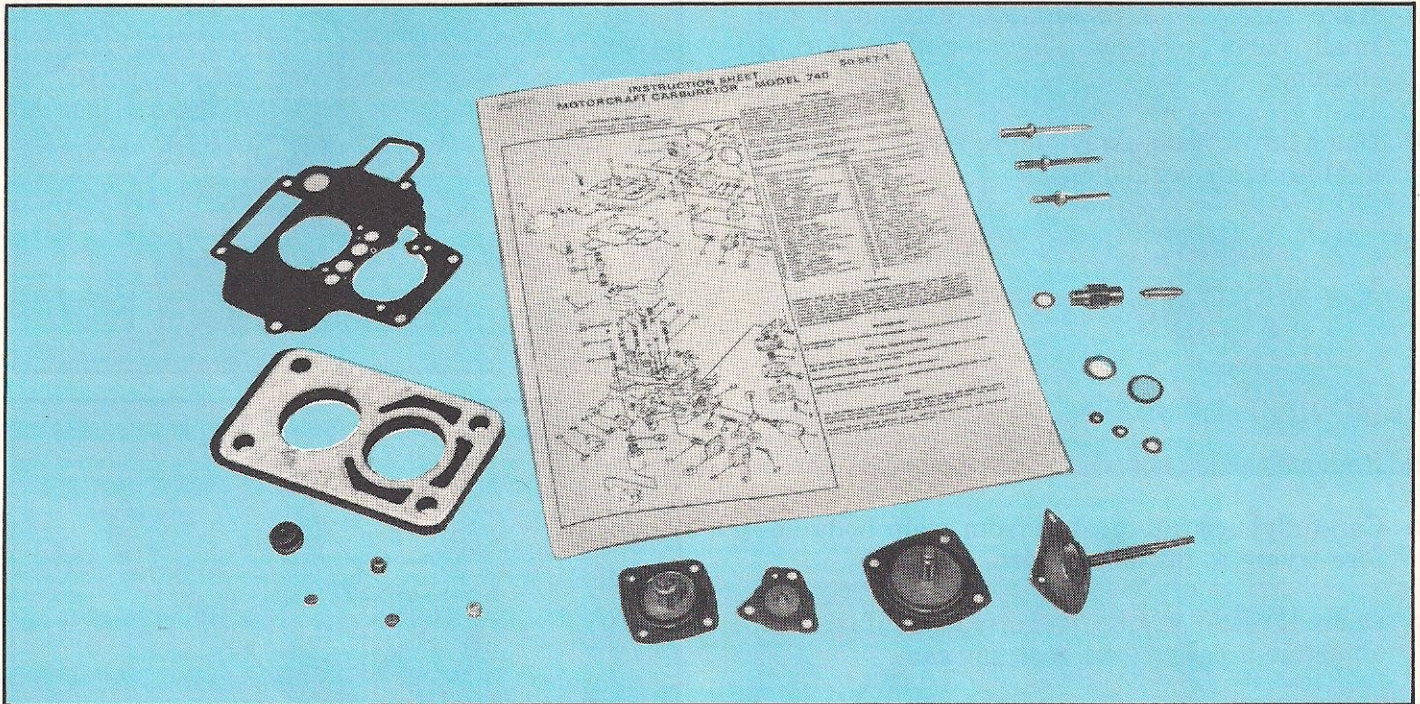

- Motorcraft Tune-Up Kit for Model 740 Carburetor includes:
- New diaphragms for
  - Accelerator pump
  - Choke pulldown motor
  - Power enrichment valve
  - Throttle kicker
- New gaskets for
  - Idle fuel shutoff solenoid
  - Inlet needle seat
  - Fuel bowl vent solenoid
- New O-rings for
  - Choke housing
  - Accelerator pump nozzle
  - Idle mixture adjustment screw
- New adjustment limiting rivets for
  - Choke cover retainer
  - Pulldown motor cover
- New adjustment limiting plugs and seals for
  - Choke pulldown adjustment screw
  - Idle fuel mixture adjustment screw
- New fuel bowl vent seal
- New fuel inlet needle and seat
- Carburetor spacer assembly
- Carburetor body-to-air-horn gasket
- Instruction sheet

## NEW BRAIDED FUEL LINE

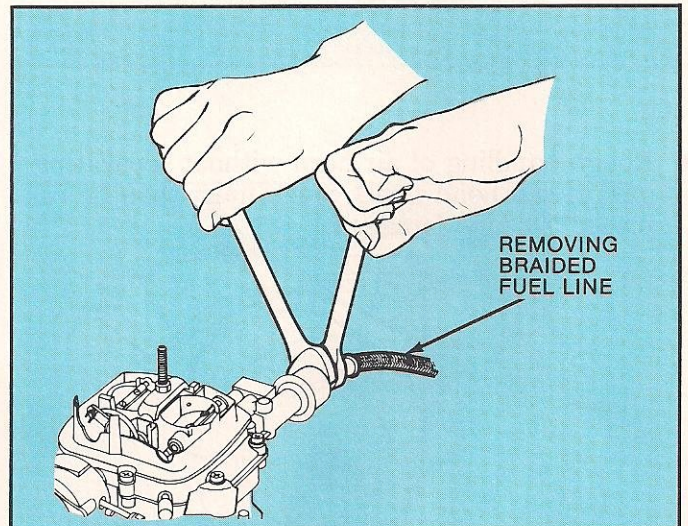

**NOTE:** Model 740 uses new braided fuel line to comply with federal standards.

- WHEN WORKING WITH THIS LINE, ALWAYS USE TWO WRENCHES TO AVOID DAMAGING IT!

## DISASSEMBLY

- ALWAYS install legs to base of carburetor before disassembling, to protect throttle plates.
- Make sure you have separate containers for small parts so they stay together during cleaning.
- Don't throw parts away before looking at parts in Motorcraft rebuilding kit.

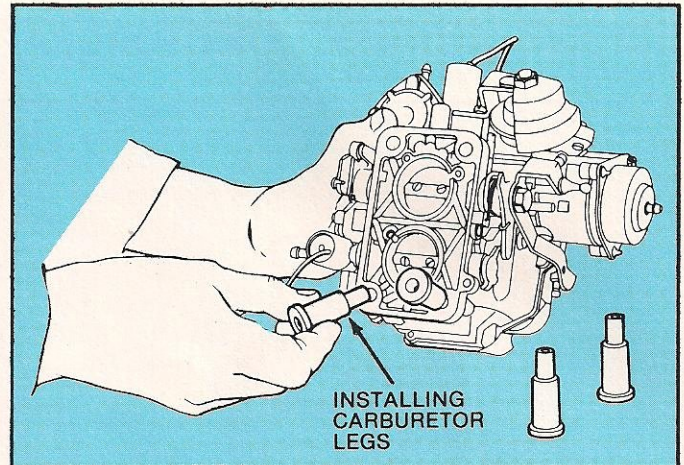

### REMOVING AIR HORN

- Remove the six screws that attach air horn.
  - Carefully separate gasket from main body before trying to lift off air horn.
  - Open throttle slightly to disengage fast idle adjustment screw from fast idle cam.
- 
- Rough handling of air horn without separating gasket can bend float, which must then be replaced if badly damaged.

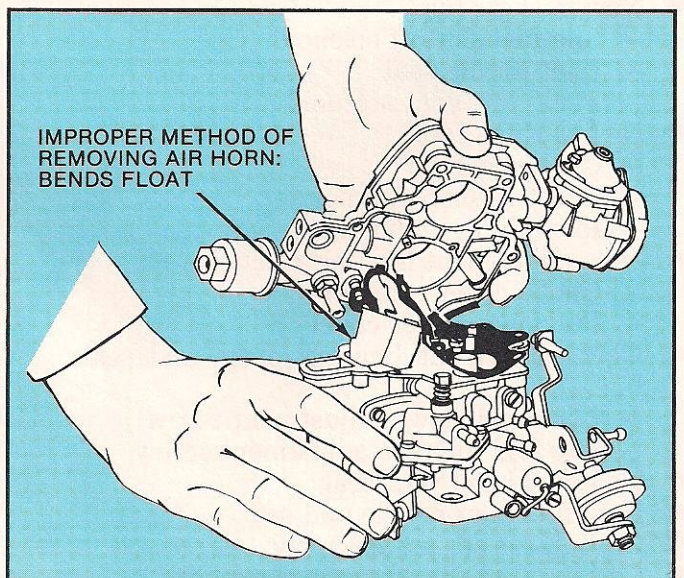
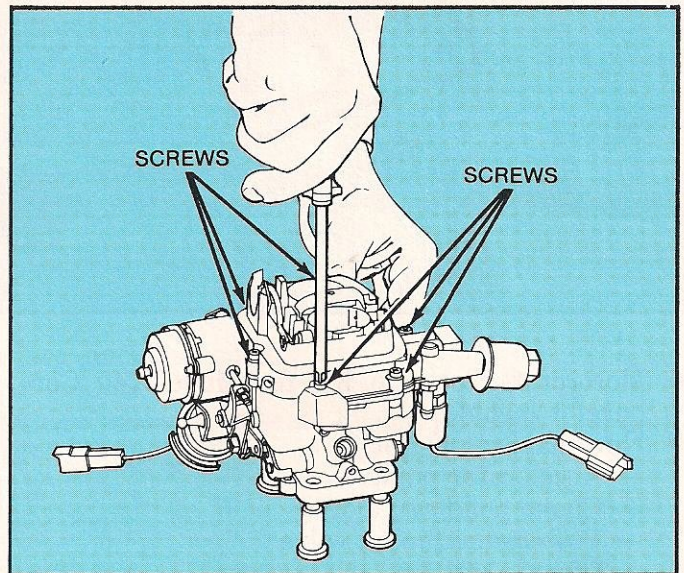

- Make sure all gasket material is removed from air horn and main body so that new gasket will seal properly.
- **BE CAREFUL** not to damage carburetor body in attempt to remove gasket material. Use only putty knife, not sharp instrument!

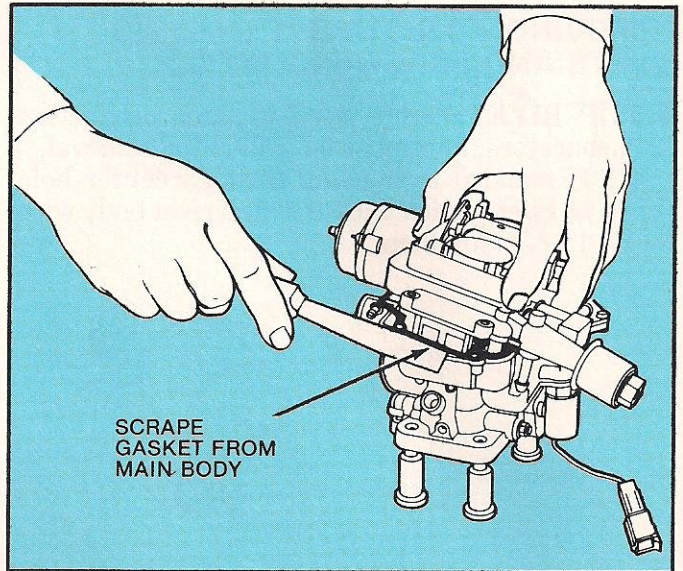

## REMOVING ADJUSTMENT LIMITING RIVETS AND SCREWS

- Before disassembling choke, adjustment limiting rivets or screws (both were used in production) must be removed.
- Only rivets will be used during reassembly (they are contained in Motorcraft Tune-Up Kit).
- **BREAKAWAY SCREWS** were used in some early production carburetors and are easily removed with the proper tools.
  - (1) Using center punch and hammer, put "dimple" in one side of cone-shaped surface.
  - (2) Tap to left (counter clockwise) until screw is loose, then remove by hand.

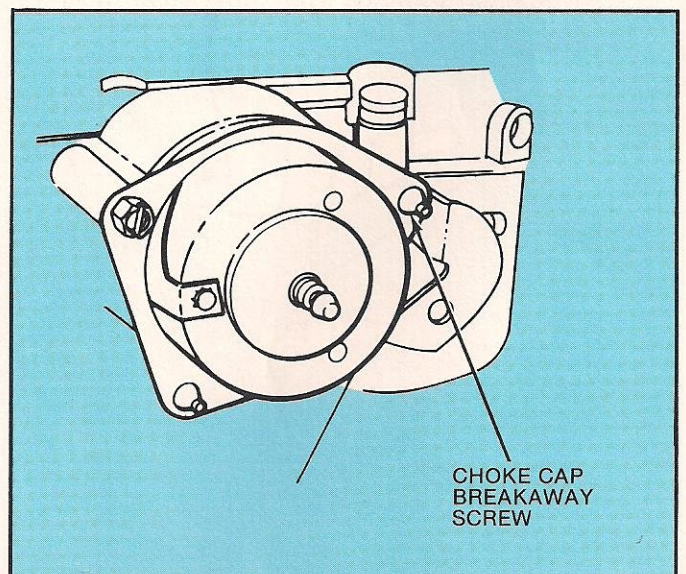
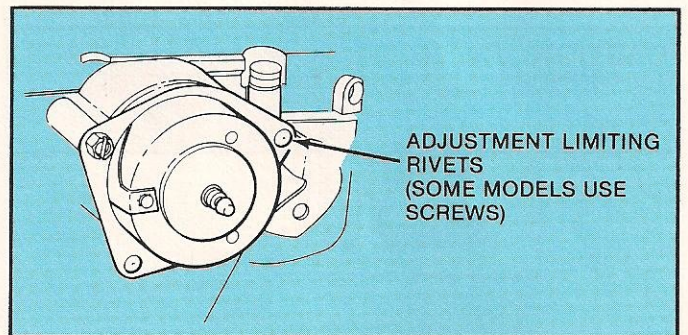

## REMOVING ADJUSTMENT LIMITING RIVETS AND SCREWS (CONT'D.)

- POP RIVETS were used in later production carburetors, and must be drilled for removal.
  - (1) If mandril is showing through center hole of rivet, punch back through rivet body with 1/16-inch punch.

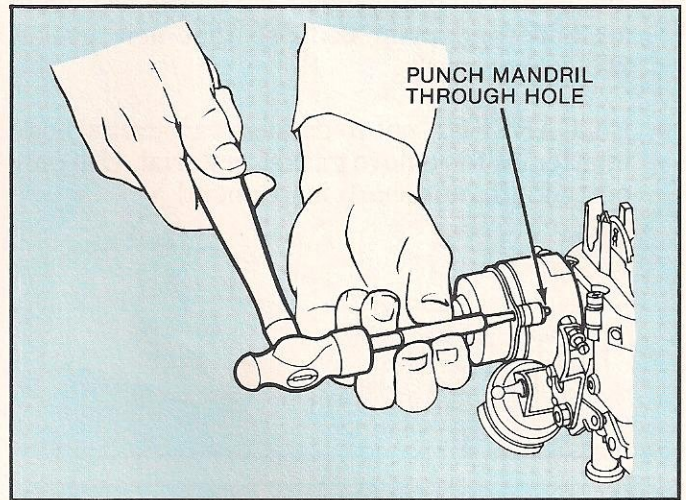

- (2) Using a 1/8-inch drill bit (0.125-inch) and light pressure, drill into the rivet until head comes loose from body.

**CAUTION:** *Too much pressure will cause drill bit to bite into and spin rivet instead of drilling.*

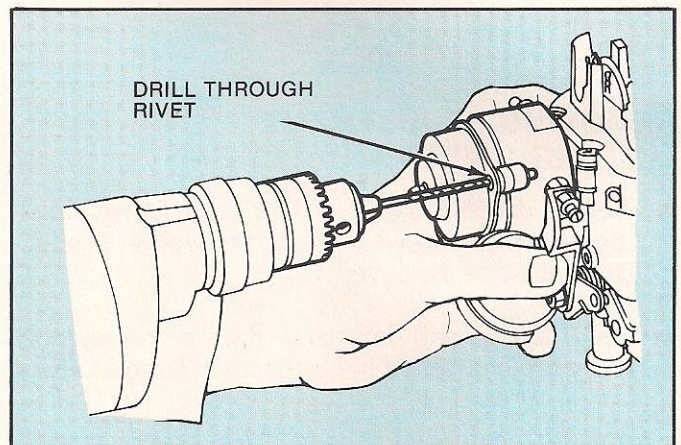

- (3) Using 1/8-inch punch, remove rivet body from hole. Remove remaining rivet in same way.

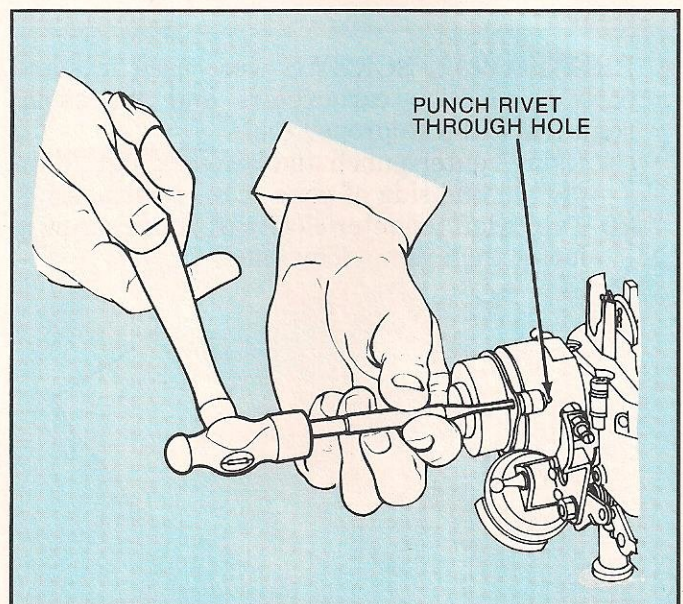

## REMOVING ADJUSTMENT LIMITING PLUGS

- Choke pulldown adjustment and idle mixture adjustment screws are sealed with adjustment limiting plugs.
- INNER PLUG is plastic and is used to hold adjustment screw in position after adjustment; OUTER PLUG is hardened steel and is used to limit adjustment by unauthorized personnel.
- To remove the plugs in the pulldown diaphragm cover, first remove the cover, grasp the back of the adjustment screw with pliers and then screw out. Wear protective glasses and using a punch and hammer drive the plugs out.
- To remove the idle mixture plug, first center punch and drill with a 3/32 drill through both the hardened steel outer plug and plastic inner plug, then remove both plugs with an easyout.

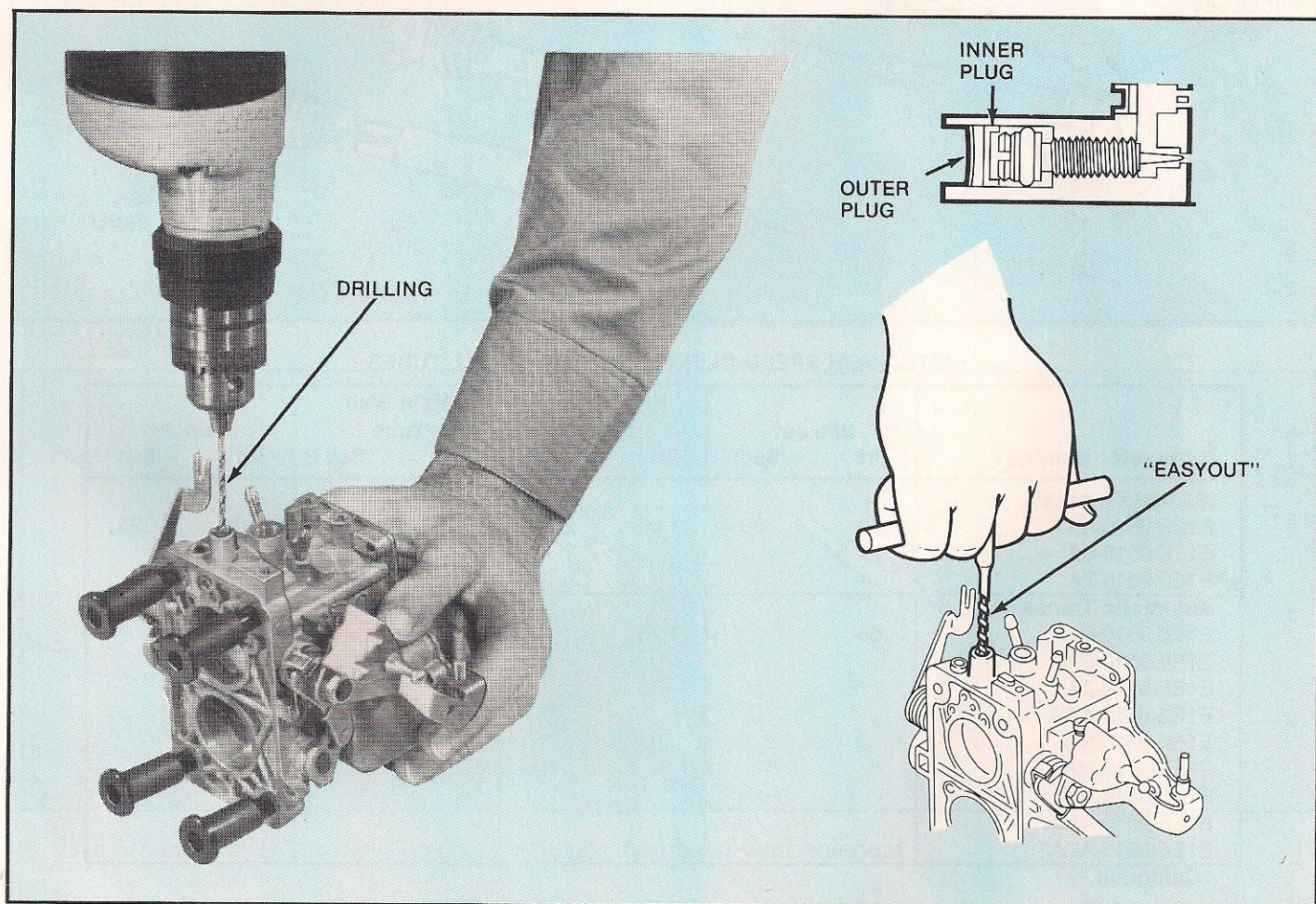
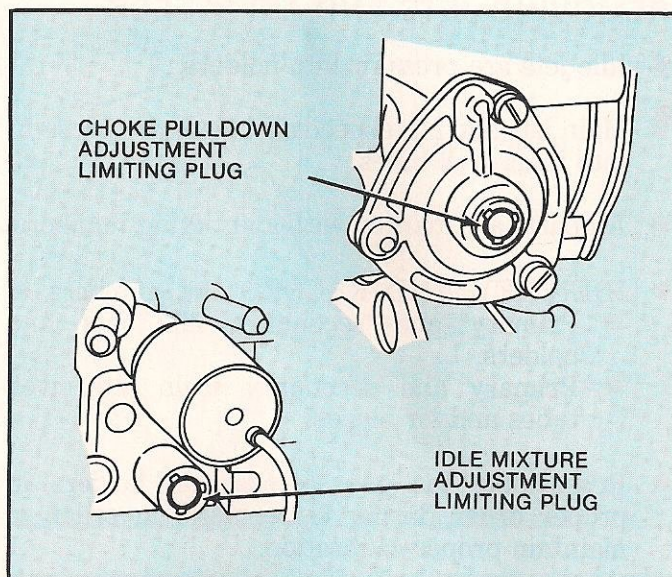

## REMOVING JETS AND AIR BLEEDS

- Idle jets are press-fit into holders.
- Main jets and high speed air bleeds are press-fit into main well tubes.
- All parts are marked with identifying numbers.
- IDENTIFY AND RECORD the numbers of
  - Primary and secondary idle jets and holders.
  - Primary and secondary main jets, well tubes and air bleeds.
- Reassemble the jets, bleeds and holders in proper order during reassembly, in order to maintain proper calibration.

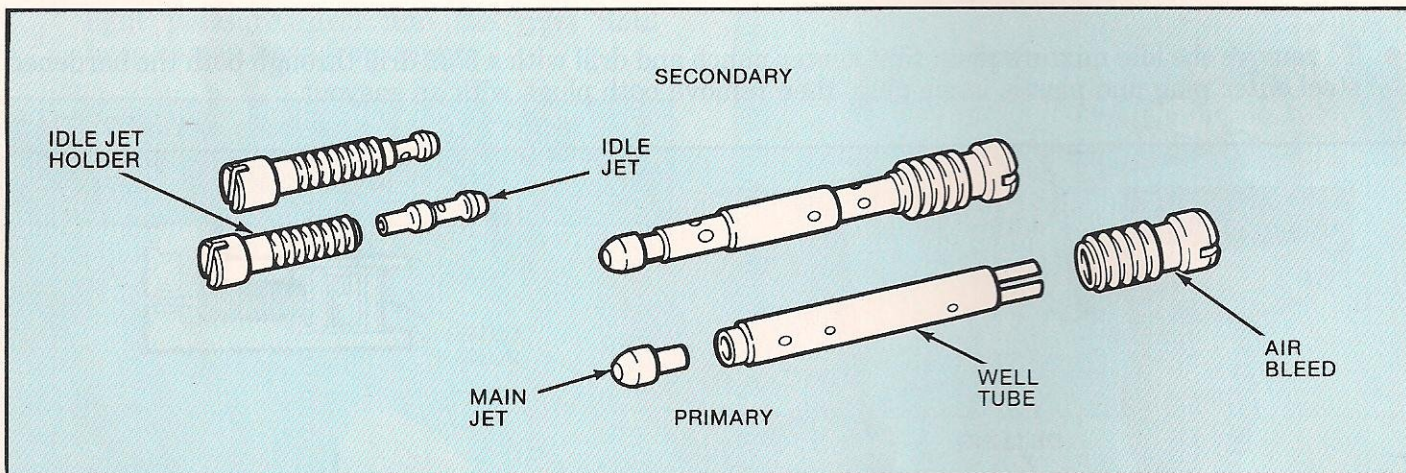
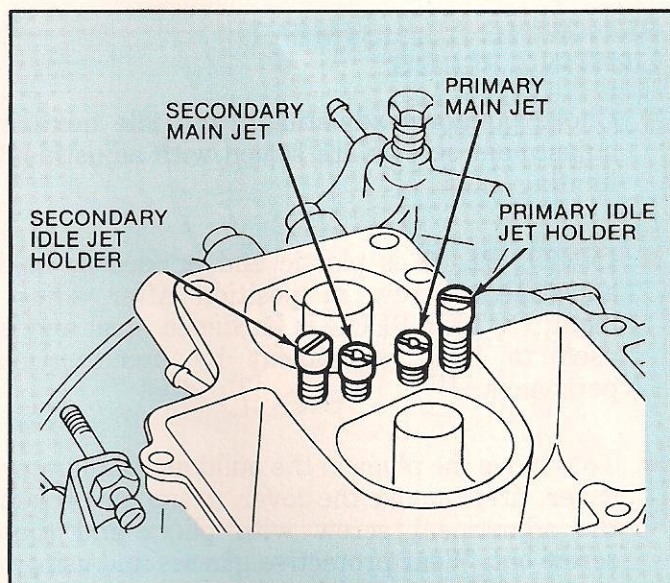

JETS, HIGH SPEED BLEEDS AND MAIN WELL TUBES

Carburetor Number	Idle Jet		High Speed Bleed		Main Well Tube		Main Jet	
	Pri	Sec	Pri	Sec	Pri	Sec	Pri	Sec
<b>Manual Transaxle</b> E1EE-9510-AAA E1EE-9510-SA E1EE-9510-TA	.50	.60	1.60	2.20	X05	T02	1.05	.95
<b>Automatic Transaxle</b> E1EE-9510-RA E1EE-9510-PA E1EE-9510-ZA E1EE-9510-ACA E1EE-9510-NA E1EE-9510-NA E1EE-9510-MA E1EE-9510-AMA* E1EE-9510-ALA*	.55		1.75				1.07	1.05

\*California



**REMOVING ACCELERATOR PUMP NOZZLE**

- Remove accelerator pump nozzle with needle-nosed pliers.
- Remove O-ring from nozzle.

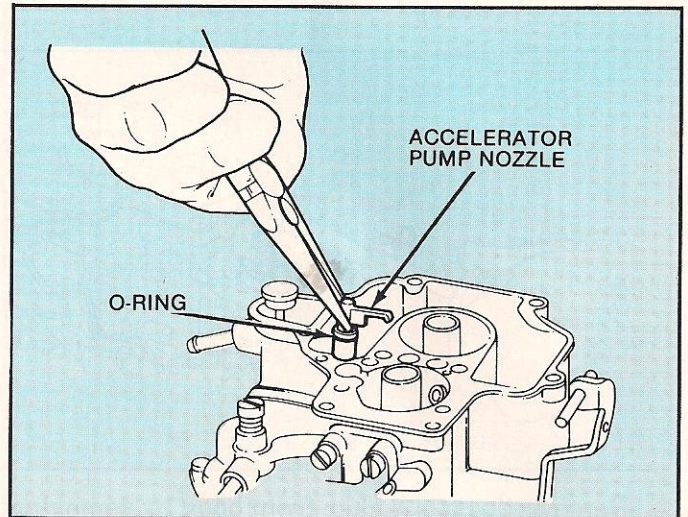
**REMOVING IDLE FUEL SHUTOFF SOLENOID**

- Use Tool T81P-9510-A and 3/8-inch ratchet to remove idle fuel shutoff solenoid without damaging it.

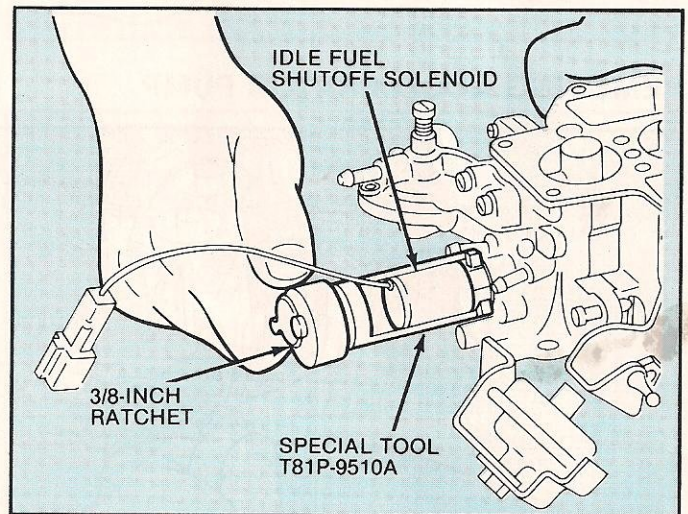
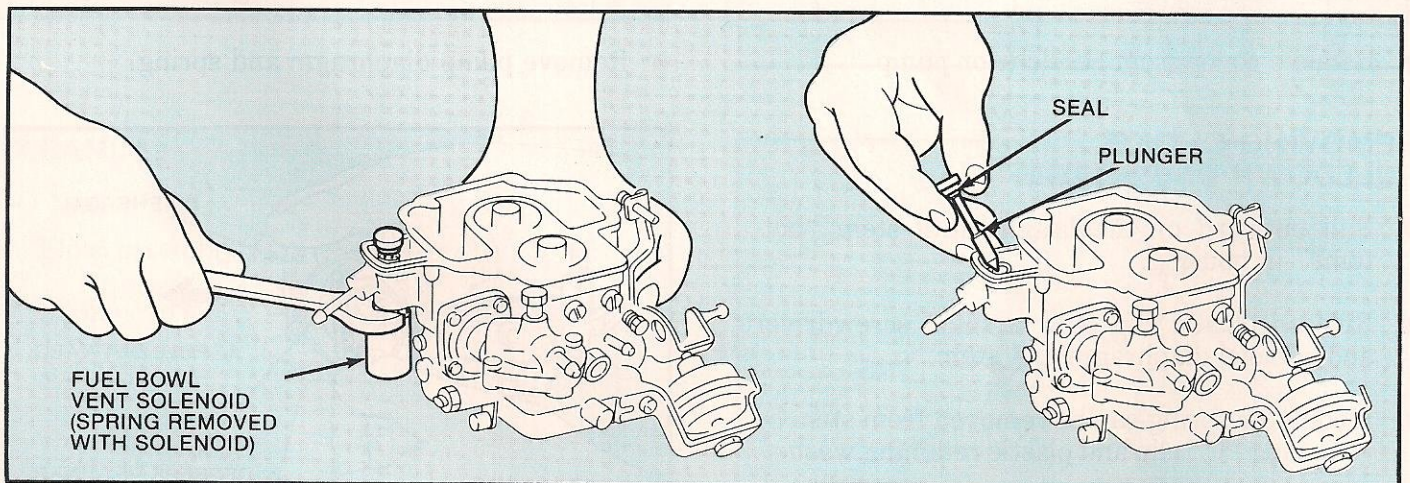
**REMOVING FUEL BOWL VENT SOLENOID**

- Use 5/8-inch or 16 mm end wrench to loosen fuel bowl vent solenoid.
- Unscrew solenoid from bottom of main body, remove spring, plunger and seal from top of main body.

# DISASSEMBLY AND ASSEMBLY

www.carburetor-parts.com

## REMOVING THROTTLE KICKER

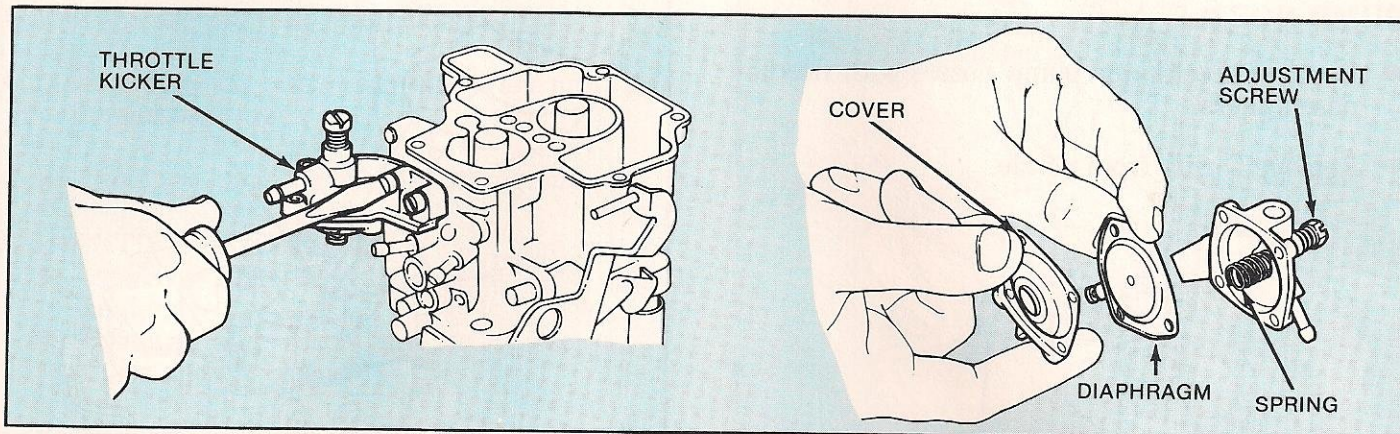

- Remove throttle kicker from body by removing attaching screws.
- Disassemble throttle kicker by removing cover screws and removing diaphragm and spring.

## REMOVING ACCELERATOR PUMP

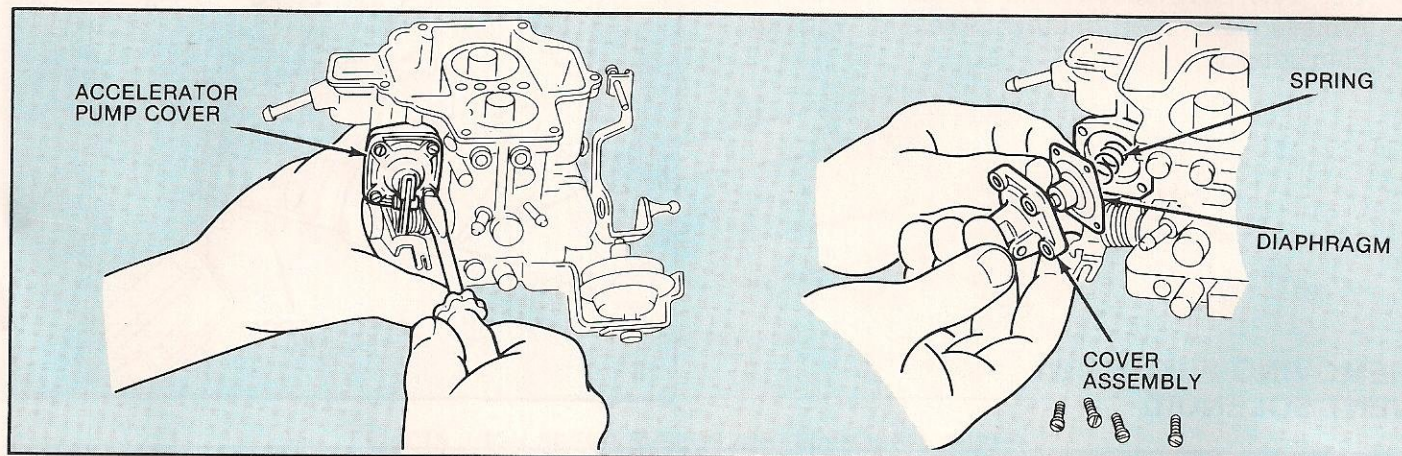

- Remove cover from accelerator pump.
- Remove pump diaphragm and spring.

## REMOVING CHOKE PULLDOWN DIAPHRAGM

- Pull outward on diaphragm until stem "bottoms" in housing.
- Release plastic clip with a small screwdriver and remove diaphragm and stem.
- Modulator spring can be removed from stem by removing "C" clip and plastic retaining washer.

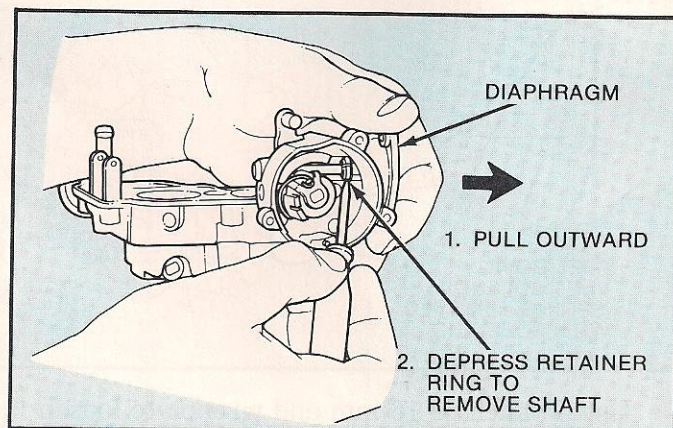

**REMOVING POWER ENRICHMENT VALVE DIAPHRAGM**

- Remove cover from power enrichment valve.
- Remove diaphragm and return spring from body.

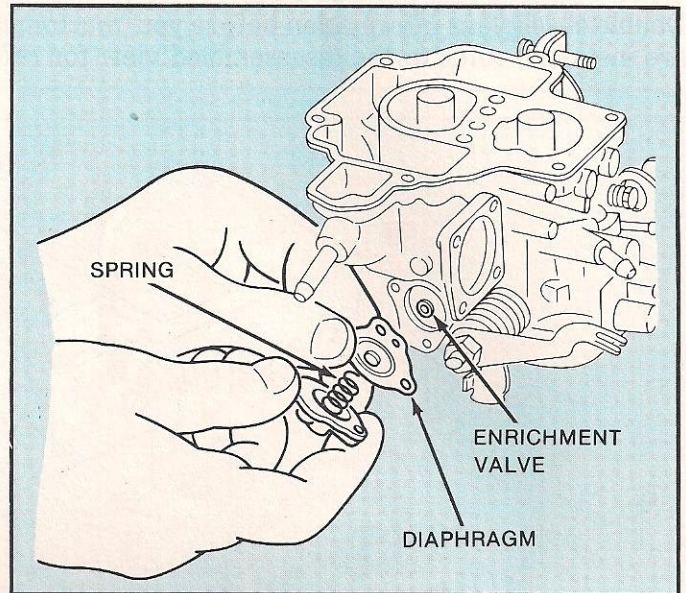
**REMOVING CHOKE ASSEMBLY**

- Remove choke body by removing three attaching screws, disengaging choke link and pulling outward on housing.
- Remove the O-ring from the vacuum passage at the rear of the housing.

**NOTE:** NEVER disassemble choke plates from choke shaft, or throttle plates from throttle shaft, as they are positioned in production.

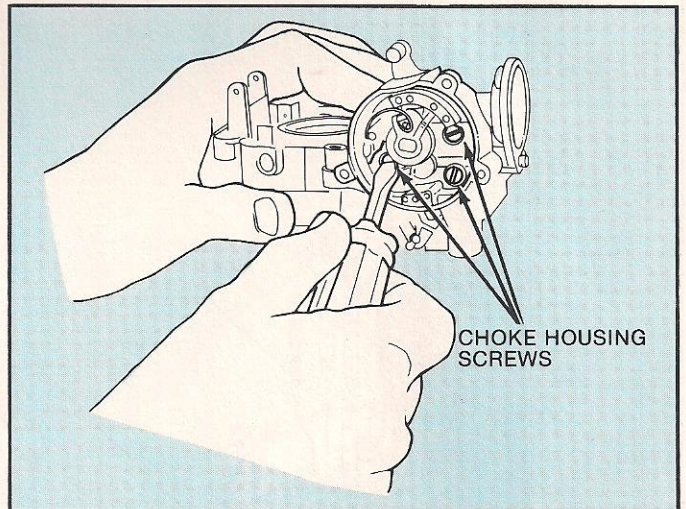
**CLEANING**

DO NOT SOAK:

- Float assembly
- Choke cap
- Diaphragms
- Solenoids
- Parts with rubber

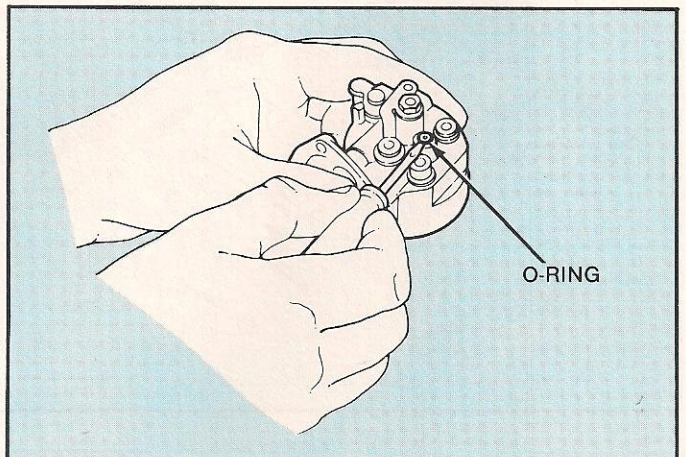

# DISASSEMBLY AND ASSEMBLY

www.carburetor-parts.com

## ASSEMBLY

When reassembling the carburetor, refer to your notes concerning which parts go where during assembly. Double check your information **before** you "button up" the carburetor. If in doubt as to how any of the parts are installed, refer to the disassembled view for reference.

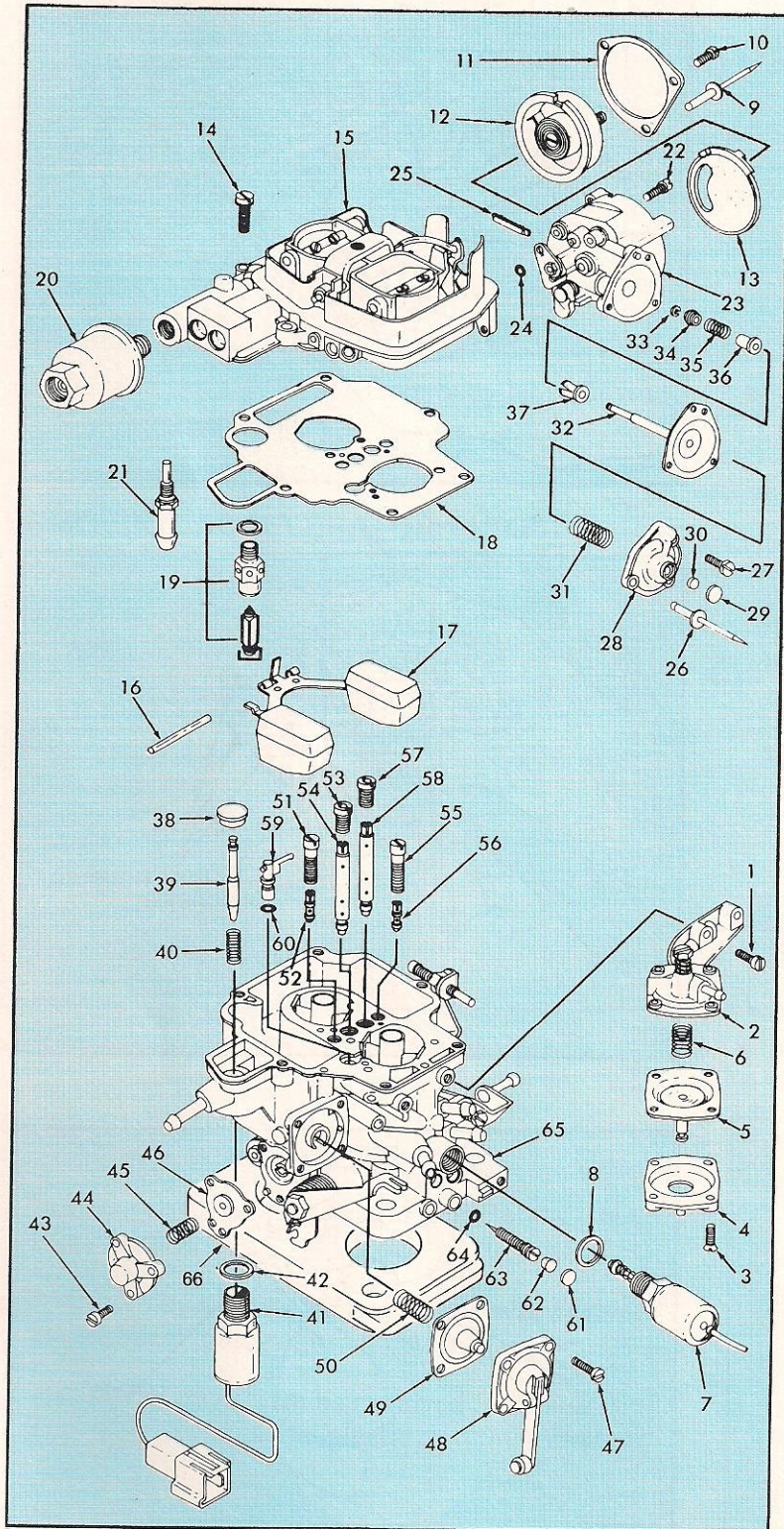

1. Screw and lockwasher (2) — Throttle kicker
2. Throttle kicker assembly
3. Screw (4) — Cover
4. Cover — Diaphragm
5. Diaphragm assembly — Throttle kicker\*
6. Spring — Diaphragm
7. Solenoid — Idle shutoff
8. Gasket — Solenoid
9. Rivet (2) — Choke cover retainer\*
10. Screw (1) — Choke cover retainer
11. Retaining ring — Choke cover
12. Electric choke cover assembly
13. Dirt shield — choke housing
14. Screw and lockwasher (6) — Air horn
15. Air horn assembly
16. Pin — float
17. Float and lever assembly
18. Gasket — Air horn\*
19. Needle, seat and gasket assembly\*
20. Filter — Fuel inlet
21. Check valve — Fuel return
22. Screw (3) — Choke housing assembly
23. Choke housing assembly
24. O-ring — Choke housing\*
25. Retainer — Choke link seal
26. Rivet — Cover\*
27. Screw (2) — Cover
28. Cover — Diaphragm
29. Plug — Adjusting screw\*
30. Plug — (Plastic) Adjusting Screw\*
31. Spring — Diaphragm
32. Diaphragm assembly — Choke Pulldown\*
33. E-clip — Bushing retainer
34. Bushing (small) — Bumper spring
35. Spring — Bumper
36. Bushing (large) — Bumper spring
37. Bushing — Guide
38. Seal — Bowl vent\*
39. Plunger — Bowl vent seal
40. Spring — Seal plunger
41. Solenoid — Bowl vent
42. Gasket — Bowl vent solenoid\*
43. Screw (3) — Cover
44. Cover — Power enrichment valve
45. Spring — Power enrichment valve diaphragm
46. Diaphragm assembly — Enrichment valve\*
47. Screw (4) — Cover
48. Cover — Pump diaphragm
49. Diaphragm assembly — Accelerator pump\*
50. Spring — Diaphragm return
51. Holder — primary idle jet
52. Jet — Primary idle
53. Air bleed — Primary
54. Tube — Primary main well
55. Holder — Secondary idle jet
56. Jet — Secondary idle
57. Air bleed — Secondary
58. Tube — Secondary main well
59. Nozzle assembly — accelerator pump discharge
60. O-ring — Pump nozzle\*
61. Plug — Idle fuel mixture needle\*
62. Plug (plastic) — Idle fuel mixture needle\*
63. Needle — Idle mixture adjustment
64. O-ring — Idle mixture adjustment needle\*
65. Main body assembly
66. Spacer and gasket assembly\*

\*Included in Motorcraft Tune-Up Kit

## ADJUSTMENT

### INSTALLING ADJUSTMENT LIMITING RIVETS AND PLUGS

#### ADJUSTMENT LIMITING RIVETS

- Loosely install choke cover retainer with attaching screw.

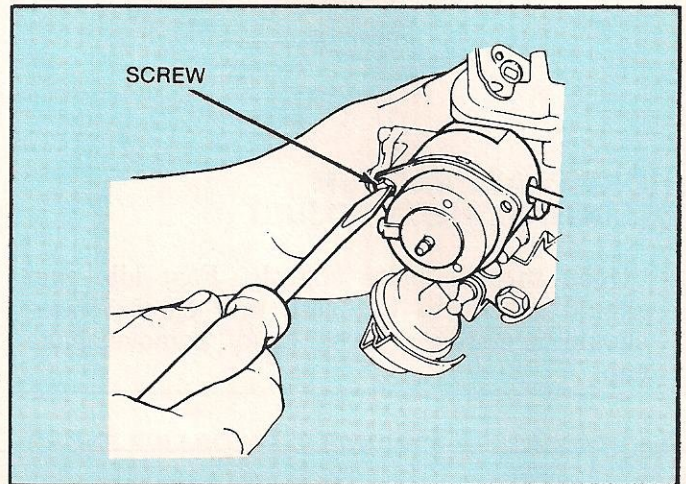

- Using "pop rivet" gun D79P-53700-A with special nose piece D80P-53700-A (or equivalent pop rivet tool) install a rivet lightly into one of the vacant retainer ring holes. DO NOT INSTALL RIVETS IN "BLIND" HOLES.
- Install a second rivet in the same way, pressing rivet snugly against the retaining ring.

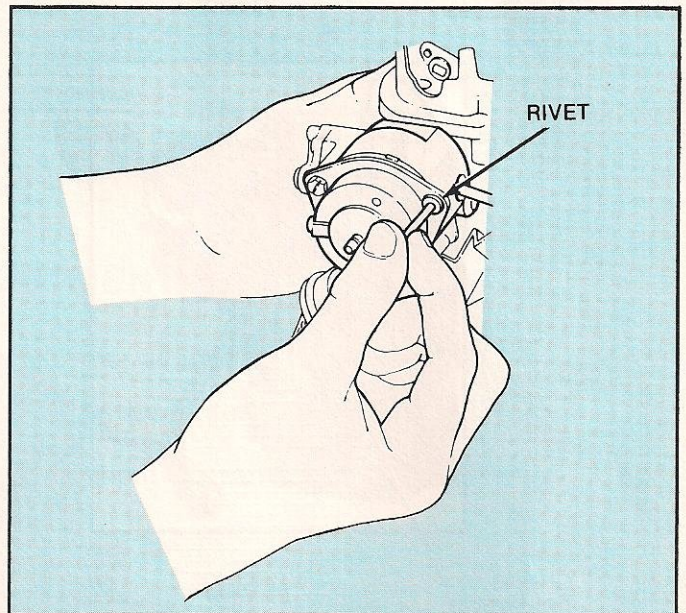

- Reposition rivet gun over mandril of first rivet and fully trigger rivet until mandril snaps off. Do the same with other rivet.
- Tighten retainer attaching screw.

Adjustment limiting rivet is installed in choke pulldown diaphragm cover in same way.

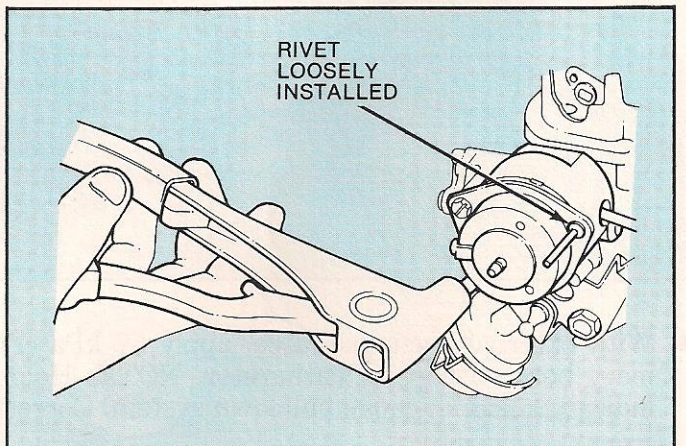

## INSTALLING ADJUSTMENT LIMITING RIVETS AND PLUGS

### ADJUSTMENT LIMITING RIVETS

- Loosely install choke cover retainer with attaching screw.
- Using "pop-rivet" gun D79P-53700-A with special nose piece D80P-53700-A (or equivalent pop rivet tool) install a rivet lightly into one of the vacant retainer ring holes. **DO NOT INSTALL RIVETS IN "BLIND" HOLES.**
- Install a second rivet in the same way, pressing rivet snugly against the retaining ring.
- Reposition rivet gun over mandril of first rivet and fully trigger rivet until mandril snaps off. Do the same with other rivet.
- Tighten retainer attaching screw.

Adjustment limiting rivet is installed in choke pulldown diaphragm cover in same way.

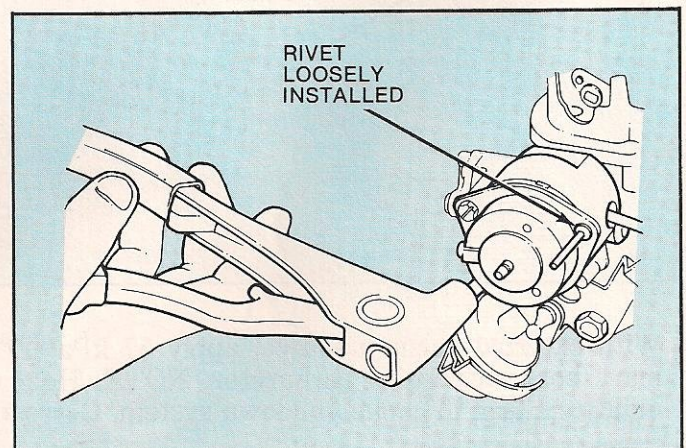
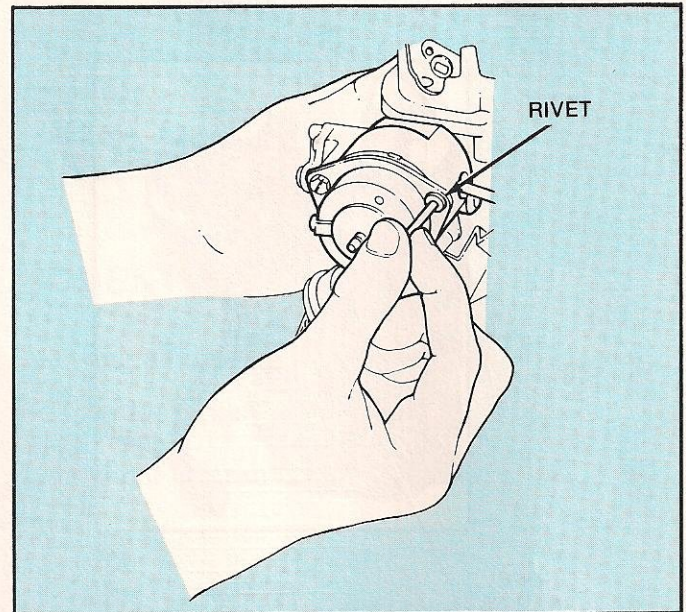
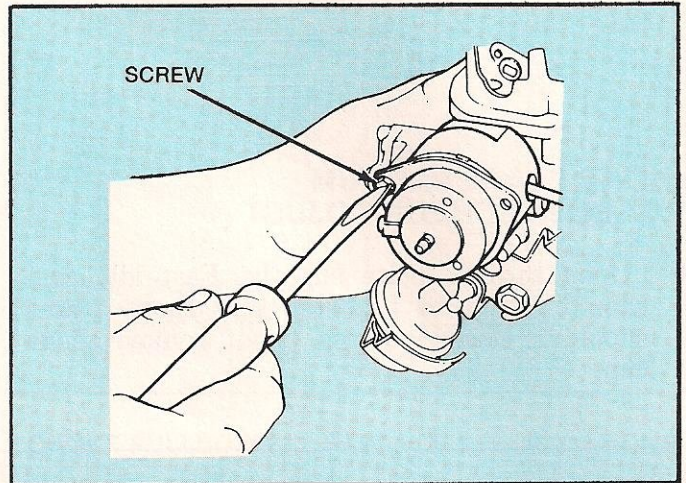

## CHOKE PULLDOWN CLEARANCE

After reassembly, there is one adjustment that can be made before the carburetor is reinstalled on the vehicle: choke pulldown clearance.

### CHOKE PLATE VACUUM PULLDOWN CHECK/ADJUST

- Open throttle plate slightly. Fast idle cam should rotate to top step and choke plates should be closed in bores. If not, remove choke cap.

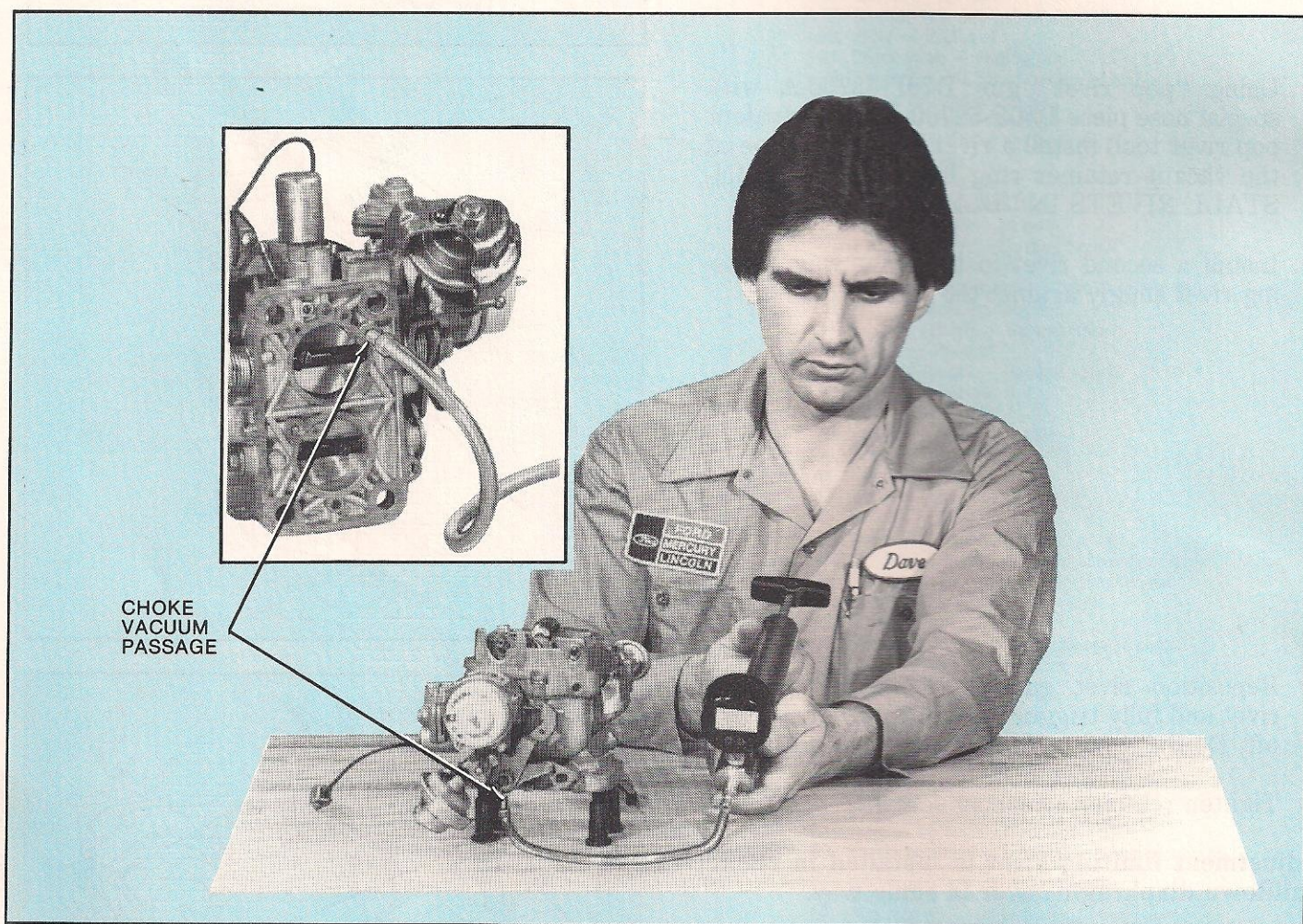
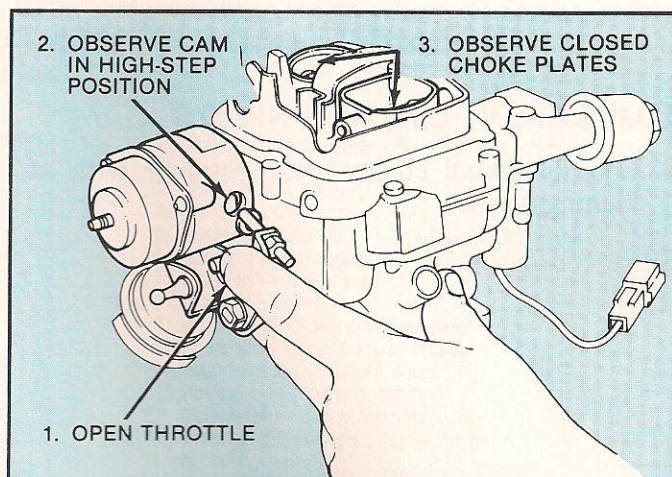

- With external vacuum source, apply 57 kPa (17 inches) Hg. of vacuum to channel adjacent to primary bore on base of carburetor. NOTE: Hold vacuum trapped and watch for leakdown that may indicate a leak in choke pulldown system. Correct before proceeding.

- With proper drill bit, check clearance between downstream edge of primary choke plate and air horn wall.
- If adjustment is required, turn the vacuum motor diaphragm adjusting screw to increase or decrease pulldown and then recheck using vacuum pump.
- When pulldown clearance is correct, install new plastic plug over head of adjustment screw, install new hardened steel plug and stake in position, 3 places.

**SYMPTON DIAGNOSIS:** *Insufficient clearance may result in loading, rough idle and/or stalls. Too much clearance may cause stalls after start (within 2 seconds), and/or backfires (induction).*

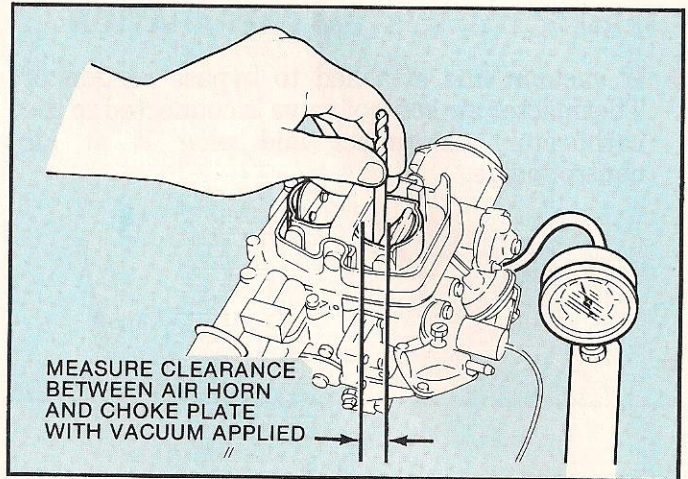

**CHOKE PULLDOWN CLEARANCE SPECIFICATIONS**

Carburetor Number (-9510-)	Pulldown Clearance (± 0.5mm)
E1EE-LA, -SA, -TA, -AAA, -ADA, -AEA, -AFA	3.0mm
E1EE-UA, -VA	3.5mm
E1EE-MA, -NA, -PA, -RA, -ZA, -ACA, -ALA, -AMA, -AHA	4.0mm

**ON-CAR ADJUSTMENTS**

After the carburetor is reinstalled on the vehicle, the following adjustments can be made:

- Idle fuel mixture
- Throttle kicker function and RPM
- Curb idle speed
- Dashpot clearance
- Fast idle speed

Before these can be checked and adjusted, the vehicle must be prepared.

**ENGINE PREPARATION**

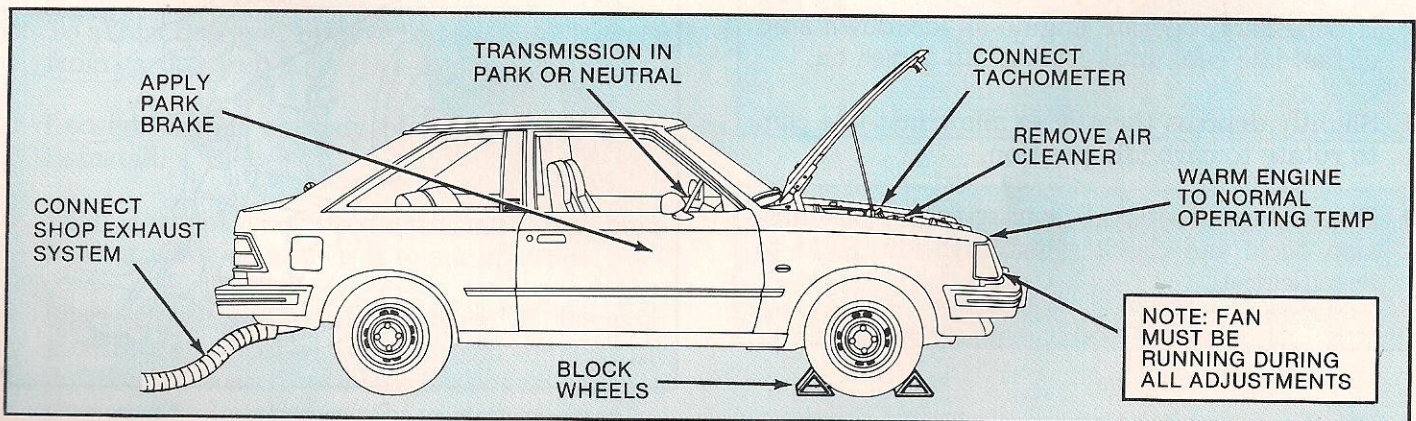



## THERMACTOR SYSTEM PREPARATION

- If vacuum line attached to bypass section of Thermoactor air control valve is connected to the carburetor, disconnect and plug it at air control valve.
- Connect a slave vacuum hose to the bypass section of Thermoactor air control valve and to intake manifold vacuum.
- Thermoactor air will now bypass during all carburetor adjustments.

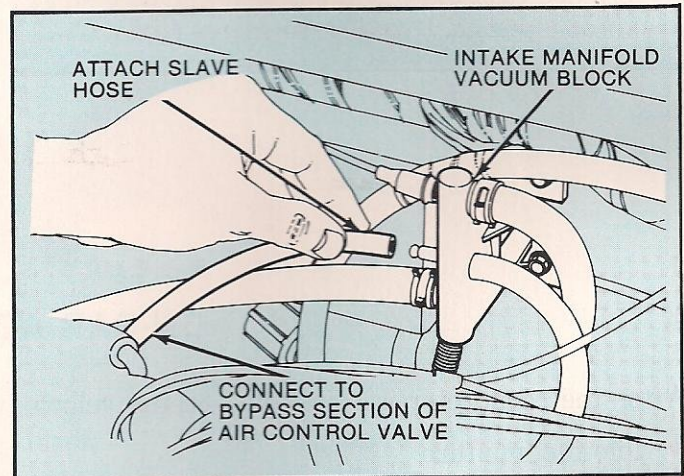
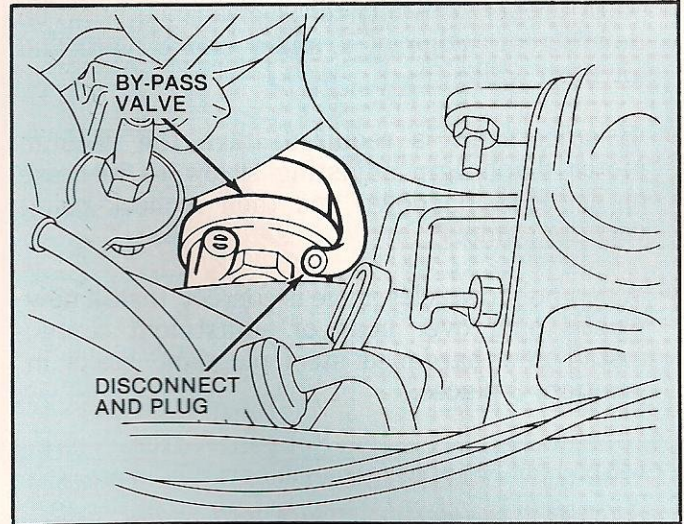

## CURB IDLE SPEED CHECK/ADJUST

**COOLING FAN MUST BE RUNNING WHEN SETTING CURB IDLE RPM.**

- If necessary, operate engine on kickdown step of fast idle cam until cooling fan comes on.
- Slightly depress throttle to allow fast idle cam to rotate to curb idle position.
- Place transmission in gear specified on emission decal and check/adjust curb idle RPM to specification.

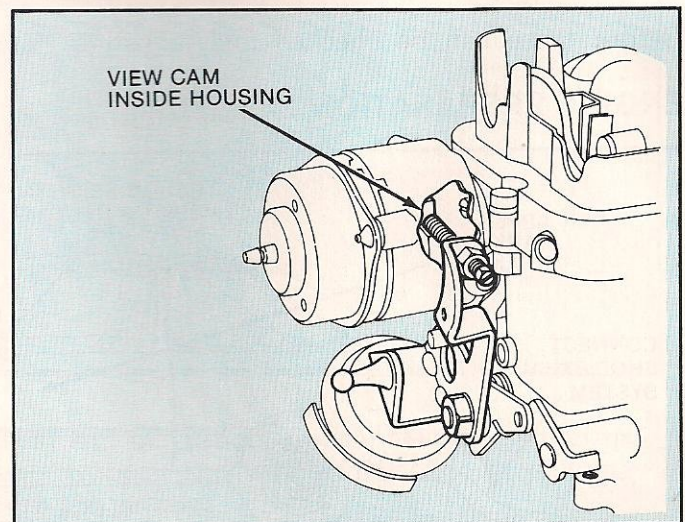

- Place transmission in Neutral or Park and increase engine RPM momentarily.
- Place transmission in specified gear and recheck curb idle RPM. Readjust if necessary.

**SYMPTOM DIAGNOSIS:** *If curb idle speed is too low, rough idle and stalls may occur. If curb idle speed is too high, vehicles with automatic transaxle will creep and vehicles with manual transaxle will have noise complaints.*

- IF IDLE RPM IS INCREASED MORE THAN 100 RPM, OR DECREASED BY ANY AMOUNT (Automatic Transaxle) YOU MUST CHECK THE TRANSAXLE TV ROD LINKAGE AND ADJUST AS NECESSARY.

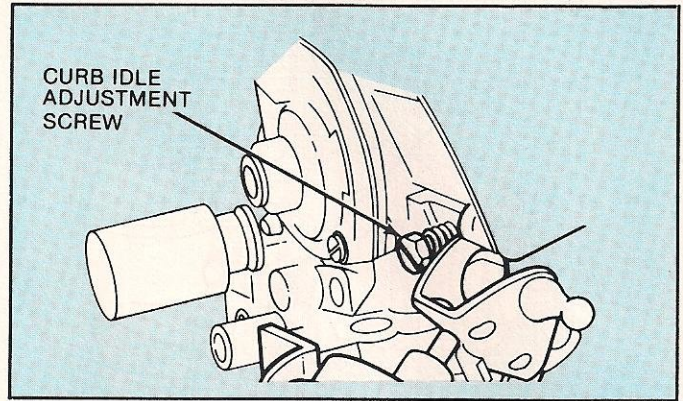

**ADJUSTING DASHPOT**

THE DASHPOT IS ADJUSTED WITH THE ENGINE OFF.

- Collapse dashpot stem and measure the clearance between the stem and the throttle lever pad, and check clearance against this chart:

DASHPOT STEM CLEARANCE	
Carburetor Number (-9510-)	Dashpot Clearance (Stem Collapsed)
E1EE-LA, -SA, -TA, -AAA, -ADA, -AEA, -AFA	3.5mm
E1EE-MA, -NA, -PA, -RA, -UA, -VA, -ZA, -ACA, -ALA, -AMA, -AHA	4.0mm

- To adjust dashpot, remove bracket and dashpot from carburetor.
- Loosen locknut so body of dashpot will turn. Reinstall.
- Turn dashpot body to adjust, and retighten locknut when clearance is to specification.
- Start engine and check operation of dashpot: as throttle is opened, stem should extend. As throttle is released, pad should contact dashpot stem and be lowered gently to curb position.

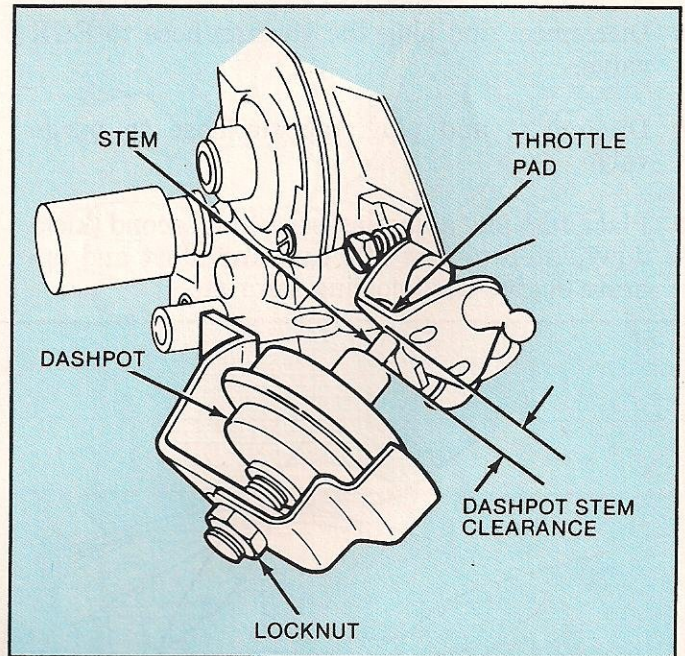

**SYMPTOM DIAGNOSIS:** *Insufficient clearance can result in high curb idle speed. Too much clearance can result in stalling when throttle is released.*

## FAST IDLE SPEED CHECK/ADJUST

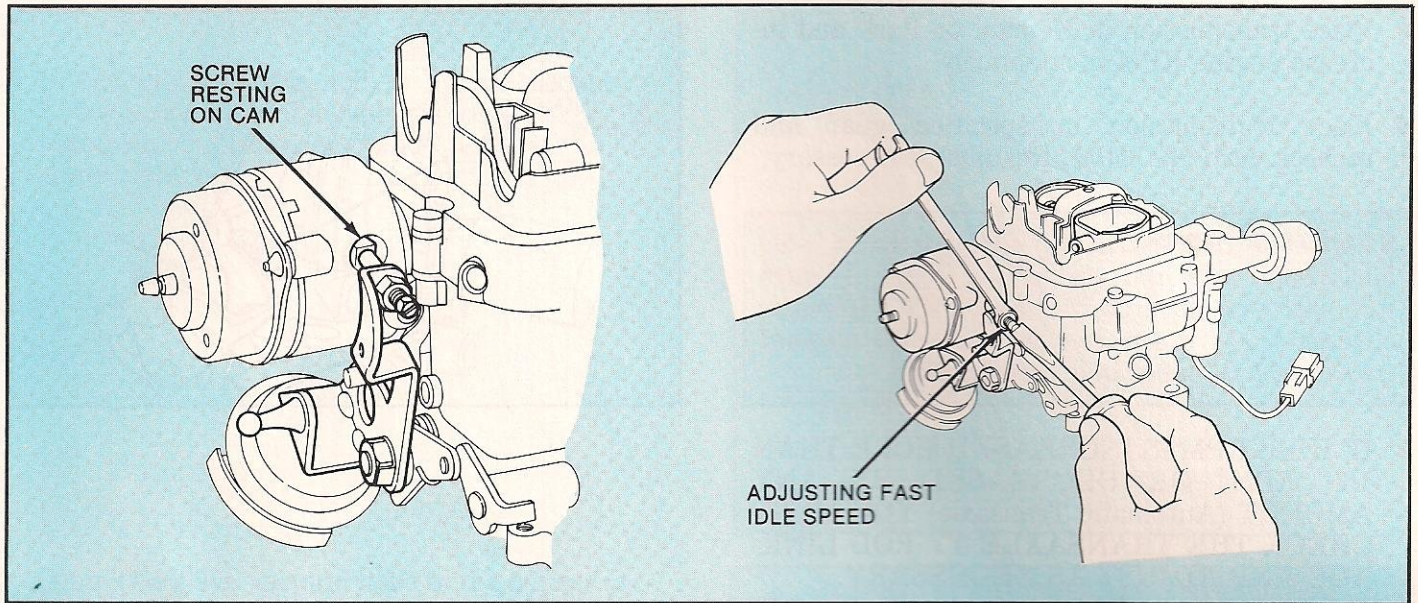

### COOLING FAN MUST BE RUNNING WHEN CHECKING/ADJUSTING FAST IDLE SPEED.

- Disconnect and plug the vacuum hose to EGR valve.
- Disconnect and plug vacuum hose to purge valve.
- Place fast idle adjusting screw on second (kick-down) step of fast idle cam and start and operate engine until cooling fan runs.

- Check fast idle RPM and adjust as necessary to match specification on engine compartment emission decal.
- To adjust, loosen locknut, make adjustment, tighten locknut.
- Unplug and reconnect vacuum hoses to EGR and purge valves.

**SYMPTOM DIAGNOSIS:** *Low fast idle speeds may cause rough idle and/or stalls. High fast idle speeds may cause vehicle creep.*

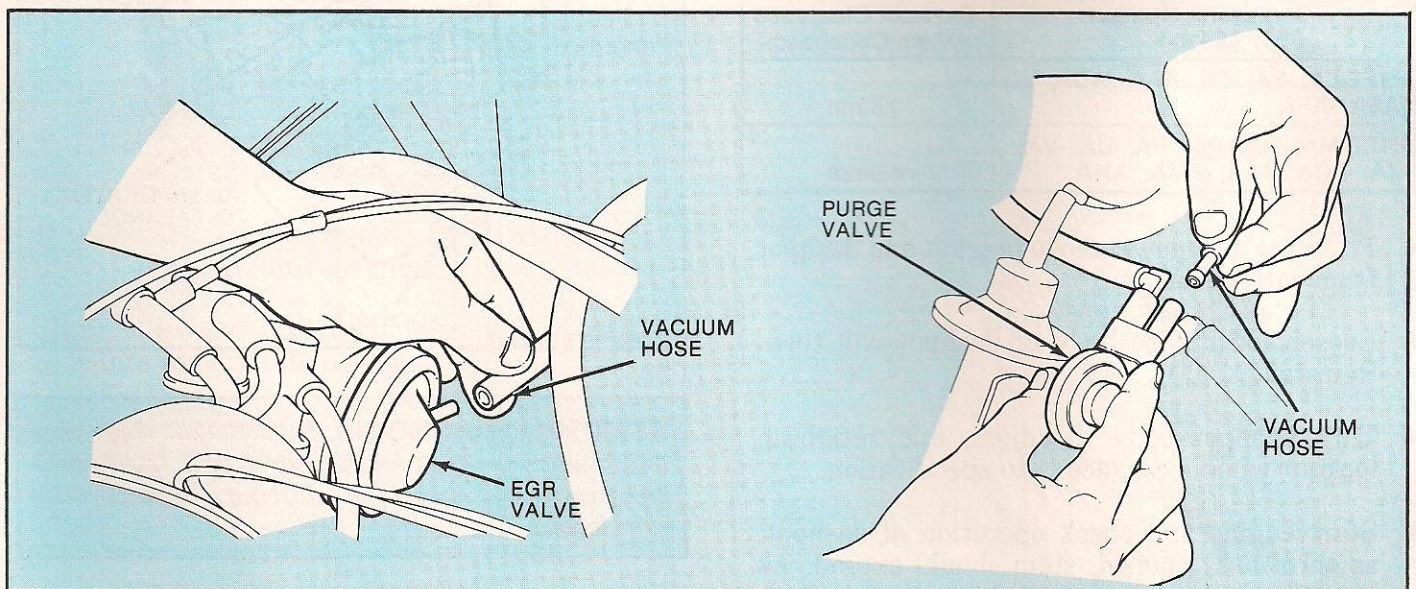

## THROTTLE KICKER

**COOLING FAN MUST BE OPERATING WHEN CHECKING/ADJUSTING THROTTLE KICKER RPM.**

- Trace vacuum hose from throttle kicker to vacuum solenoid on bulkhead and disconnect it from solenoid.
- Connect vacuum line to intake manifold vacuum at bulkhead vacuum block. With engine running, throttle kicker should operate.
- De-energize A/C clutch during throttle kicker check and adjust.
- Check engine RPM against specifications on engine compartment emission decal.
- To adjust, turn adjustment screw on top of throttle kicker. To left will increase throttle kicker ON RPM, to right will decrease throttle kicker ON RPM.
- TO CHECK OPERATION OF KICKER, disconnect vacuum line from manifold vacuum block and reconnect to vacuum solenoid.
- WITH A/C, Throttle kicker should operate when A/C control is placed in maximum cooling position and blower is on High.
- WITH POWER STEERING, throttle should operate when steering wheel is turned sharply at or near full stop position.
- WITH BOTH, system will disconnect A/C compressor clutch momentarily if power steering is loaded while A/C clutch is engaged during engine idle. When load is removed, clutch reengages.

**SYMPTOM DIAGNOSIS:** *Improper adjustment of throttle kicker will cause same indications as improper curb idle.*

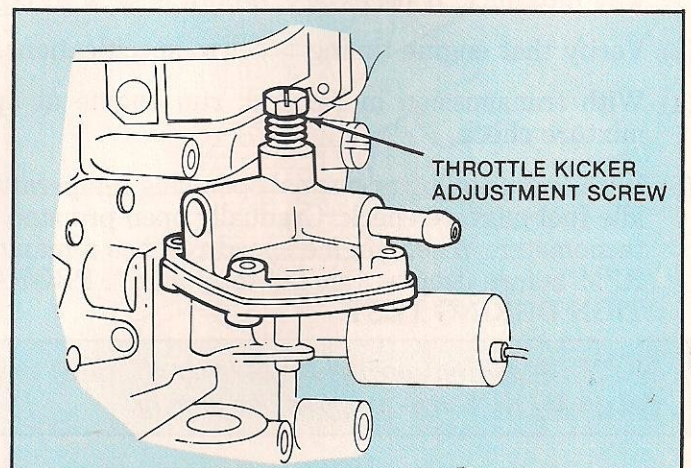
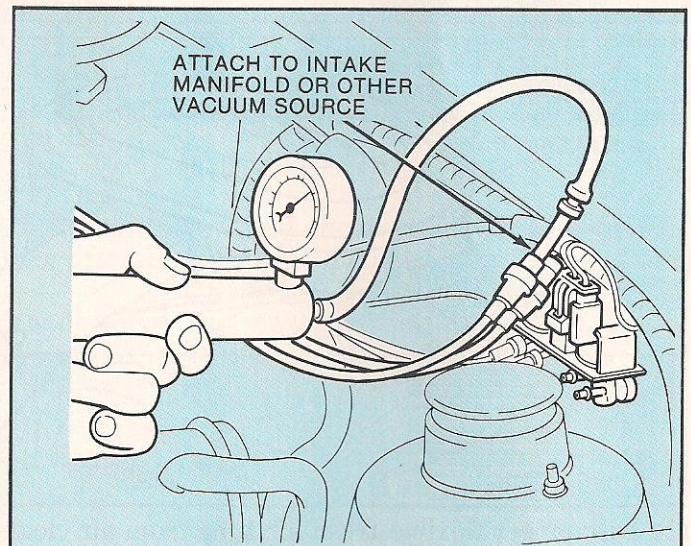
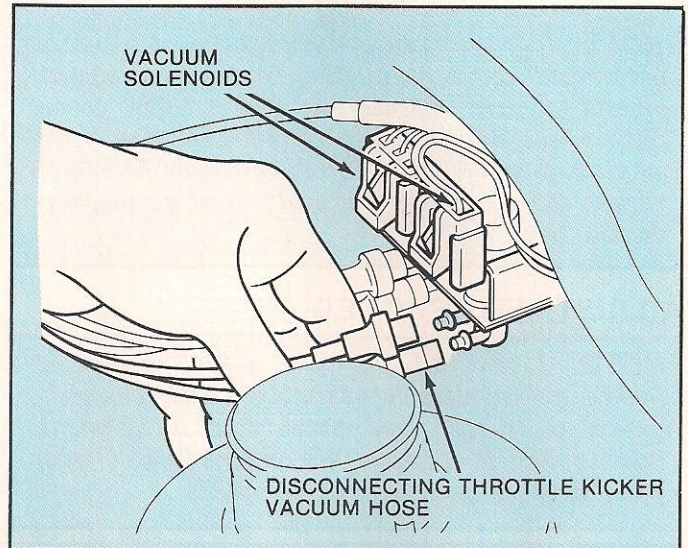

## IDLE FUEL MIXTURE — PROPANE ENRICHMENT METHOD

**NOTE:** Idle mixture check/adjustment must be performed with crankcase ventilation system opened at air cleaner or rocker arm cover. Disconnect intake manifold vacuum hose from small side of air cleaner connection or fitting on rocker cover and vent to underhood atmosphere during test.

### ADJUSTMENT PROCEDURE

**NOTE:** Leave all vacuum signal hoses attached to air cleaner assembly when relocating assembly to perform carburetor adjustments during this procedure. Air cleaner must be in place when measuring engine speeds.

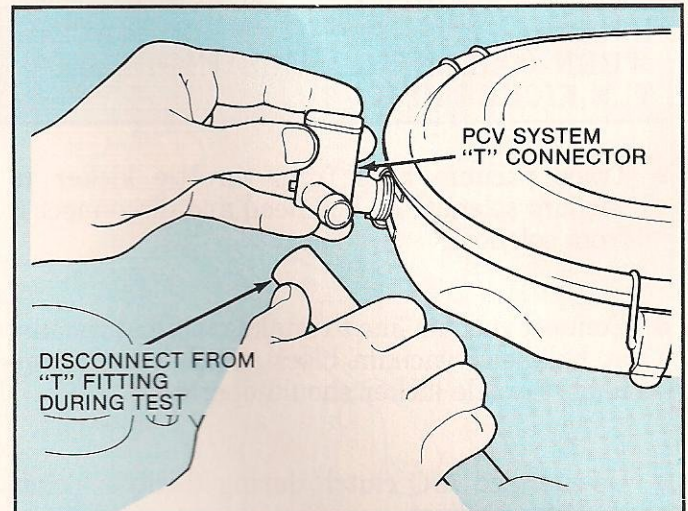

**CAUTION:** Prolonged engine idling can result in catalyst overheating and excessive underbody temperatures.

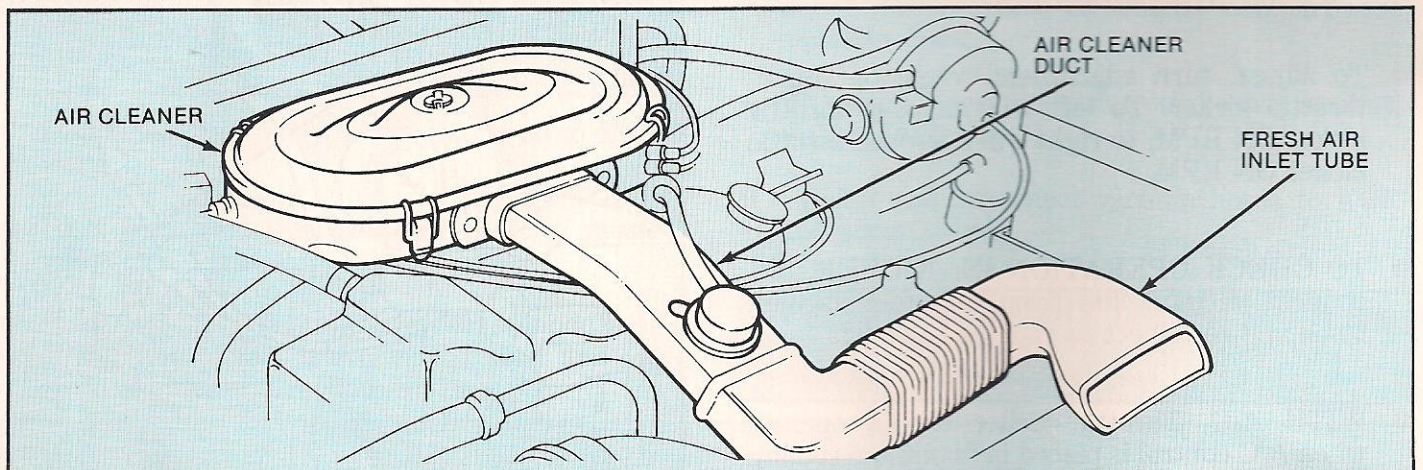

- (1) Disconnect flexible fresh air tube from air cleaner duct.
- (2) Insert hose of Rotunda T75L-9600-A propane enrichment tool or equivalent approximately 3/4 of the way into duct. If necessary, secure hose with tape.
- (3) Verify that engine timing is set to specifications.
- (4) With transmission in Neutral, run engine at approximately 2500 RPM for 15 seconds before each mixture check.
- (5) With engine idling at normal operating temperature, place transmission selector in position specified for idle fuel mixture check. Gradually open propane tool valve and watch for engine speed gain, if any, on tachometer. When engine speed reaches a maximum and then begins to drop off, note highest engine RPM before drop — this is "total gain". PROPANE CARTRIDGE MUST BE IN VERTICAL POSITION DURING TEST.

**NOTE:** If engine speed will not drop off, check propane cartridge gas supply. If necessary, repeat procedure (5) with new propane gas supply.

- (6) Compare measured speed gain to gain specified for this vehicle. If speed gain is within specification, go to step (10). If carburetor must be adjusted, adjust to "reset RPM" specification. If measured speed gain is zero RPM, (no RPM rise) and specification is "0 RPM", proceed to step (9).
- (7) If measured speed gain is too high, turn idle mixture adjusting screw counterclockwise (rich) while repeating steps (5) and (6) until the measured speed rise meets "reset RPM" specification.
- (8) If measured speed gain is too little, turn idle mixture adjusting screw clockwise (lean) while repeating steps (5) and (6) until measured speed rise meets "reset RPM" specification.
- (9) Speed Drop Test:
  - While watching tachometer, adjust mixture screw clockwise (lean) by number of turns specified for speed drop test. Note drop in engine speed.
  - If measured speed drop is equal to or greater than that specified (including a stall), return mixture screw to position before test.
  - If measured speed drop is less than minimum speed drop specification, leave mixture screw in adjusted position and repeat steps (4) through (9).
- (10) Reconnect all air cleaner hoses and ducts disconnected for test.
- (11) Recheck curb idle and, if necessary, reset to specification.

**AFTER ADJUSTING IDLE FUEL MIXTURE, CARBURETOR MUST BE REMOVED FROM ENGINE AND NEW ADJUSTMENT LIMITING PLASTIC AND STEEL PLUGS INSTALLED.**

### ADJUSTMENT LIMITING PLUGS

- Press new plastic plug over head of idle mixture adjustment screw and choke pulldown adjustment screw. It will keep engine vibration from turning screw after carburetor is installed.
- Position new tempered steel plug over adjusting screw openings and stake plug in three places.

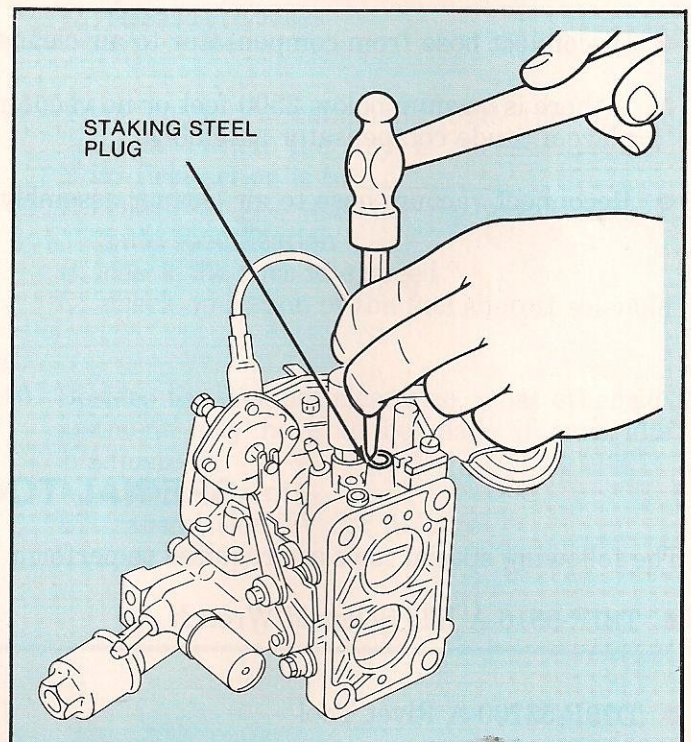
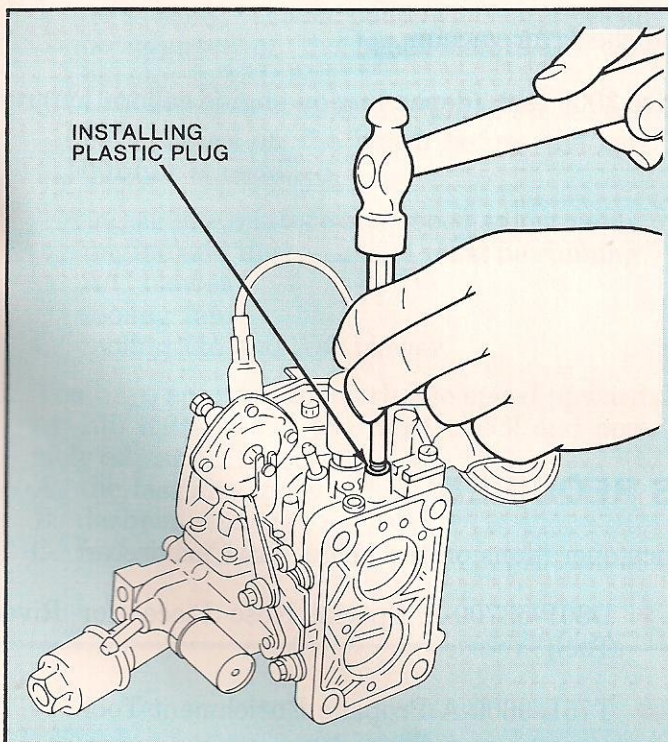

## CHECKING ALTITUDE COMPENSATION SYSTEM

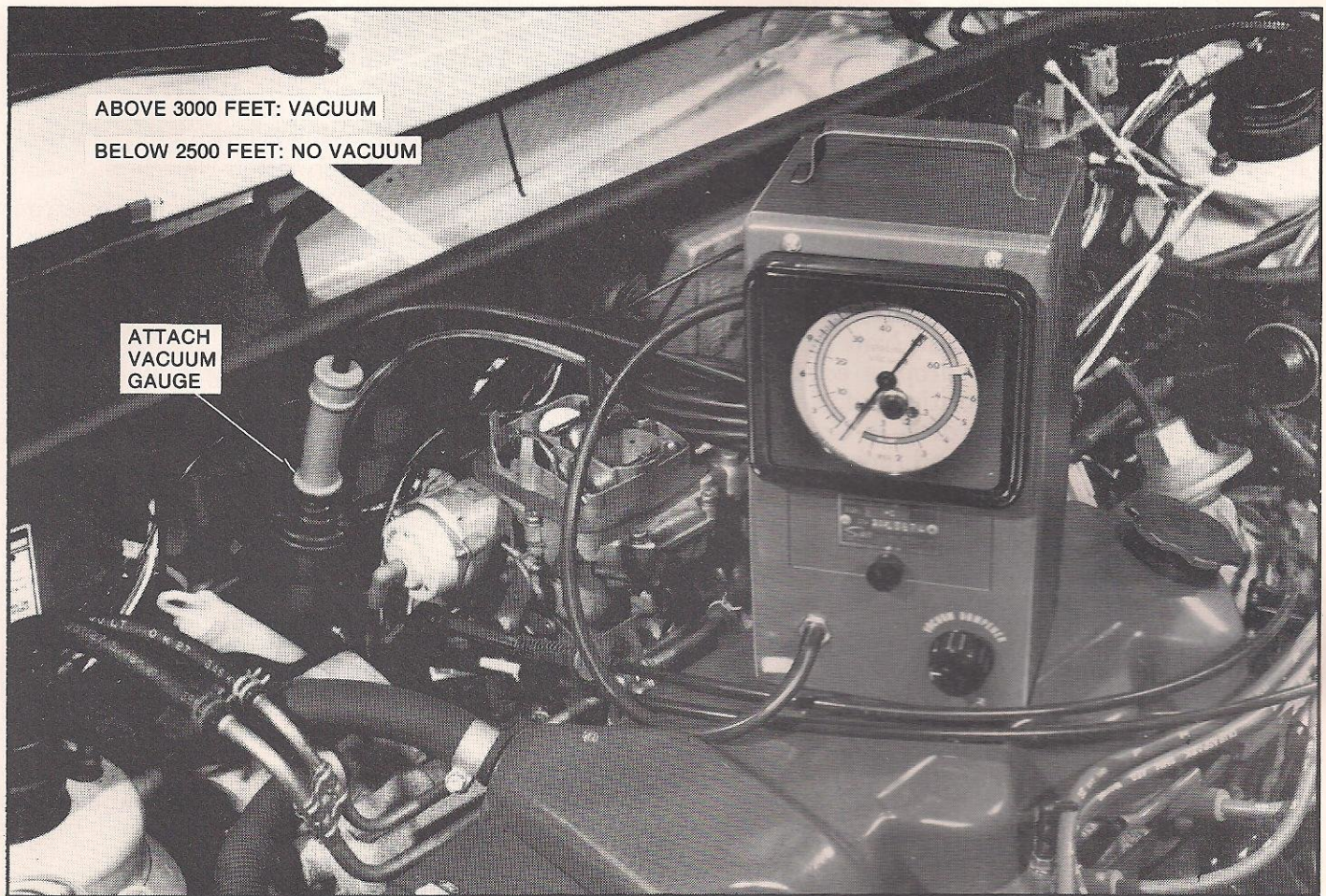

- Disconnect hose from compensator to air cleaner and check for vacuum.
- If there is vacuum below 2500 feet or no vacuum above 3000 feet, (depending on engine calibration) replace altitude compensator assembly.
- Reconnect vacuum hose to air cleaner assembly.

## SPECIAL TOOLS REQUIRED

The following special tools are required to perform service operations on the Model 740 Carburetor:

- T81P-9510-A Idle Solenoid Wrench
- D80P-53700-A Special Nose Piece (for Rivet Tool)
- D79P-53700-A Rivet Tool
- T75L-9600-A Propane Enrichment Tool